

SCHOENFELD

Headers

Performance • Quality • Value

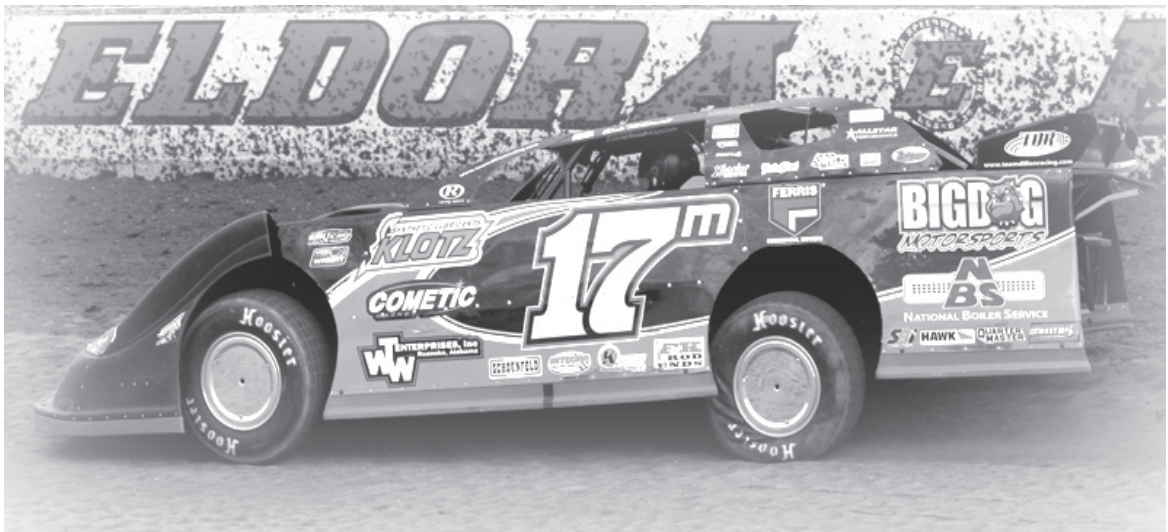

2015 RACING CATALOG

605 So. 40th St.
Van Buren, AR. 72956
Ph: 479-474-7529
Fax: 479-474-2249



Made in USA

www.SchoenfeldHeaders.com

INDEX

Small Block Chevy

Chassis.....	9,10,11
Crossover.....	3-6
Demolition Derby.....	36
Dirt Late Model.....	19-22
Dirt Late Model Tri-Y.....	19
D.I.R.T. Modified.....	34
D.I.R.T. Modified Tri-Y.....	34
Drag.....	9,10,11
IMCA-Modified.....	11-18
LS1.....	22,24,35,36
LS1 Dirt Late Model Tri-Y.....	22
Midget.....	29
Midget Tri-Y.....	29
Sprint/Dyno.....	25,26,27
Sprint/Dyno Tri-Y.....	25
Street Stock/Stock Clip.....	7-11
Truck/Tractor Pull.....	33,35,36
Zoomie.....	11

Big Block Chevy

D.I.R.T. Modified.....	34
Dyno/Sprint.....	24
Truck/Tractor Pull.....	36

Esslinger

Midget.....	31
-------------	----

Ford

2000cc & 2300cc.....	35
2000cc & 2300cc Tri-Y.....	35
Crossover.....	5,6
Demolition Derby.....	36
Dirt Late Model.....	24
D.I.R.T. Modified.....	34
IMCA-Modified.....	12,15,16,17
Sprint/Dyno.....	24,28
Stock Clip.....	8
Street Stock.....	10
Truck/Tractor Pull.....	36

Mopar

Crossover.....	4
Demolition Derby.....	36
Dirt Late Model.....	23
Midget Tri-Y.....	30
Sprint/Dyno Tri-Y.....	28
Sprint/Dyno.....	28
Truck/Tractor Pull.....	36

Micro/Mini Sprint

Yam.,Hon.,Kaw.,Suzuki.....	32,33
----------------------------	-------

Mod-Lite

Suzuki.....	33
-------------	----

Gaskets & Flanges

SB Chevy.....	38,39
BB Chevy.....	39
Collector Rings.....	41
6 Cylinder Chevy.....	39
Ford.....	39,40
Mopar.....	40
Toyota.....	39

Miscellaneous

Applications (Chassis).....	37
Applications (Elbow).....	45
Bungs.....	41
Collectors.....	42,43,45
Elbows.....	44,45
Extensions.....	44,45
U & J Bends.....	41
Header Bolts.....	41
Merge Collectors.....	42
Misc. Bends.....	41
Mufflers.....	32,46,47
Reducers.....	41,44
Special Pricing.....	37
Tab Kits.....	44
Turnouts.....	44
2x2 and 2x1 Collectors.....	45
2 Into 1 Y Pipes.....	43,45

Conventional Crossover Tri-Y

4 Into 2 Into 1 Tube Configuration for Increased Torque
 Fits Hamke, Howe, Lefthander & Port City

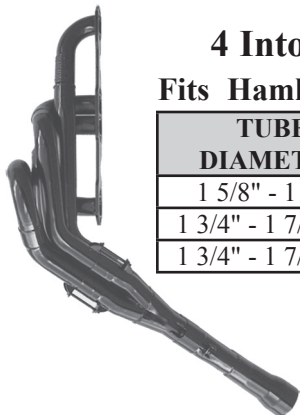

TUBE DIAMETER	COLLECTOR DIA.	STANDARD CHEVY #	*CRATE MOTOR #	CHEVY 18° #	PRICE
1 5/8" - 1 3/4"	3"	135VY	135VYCM	----	709.95
1 3/4" - 1 7/8" - 2"	3 1/2"	136V3Y	----	----	759.95
1 3/4" - 1 7/8" - 2"	3 1/2"	----	----	136V3Y18	819.95

For extension (elbow) applications see page 44-45

Available for GARC chassis
 Fits Jerico Trans.

Bolts and Gaskets included
 Comes With 5/16" Flange

* = 604 Crate Motor

Conventional Crossover Headers

SB Chevy - Fits Bemco, Hamke, Howe, Lefthander and Port City

TUBE DIAMETER	COLLECTOR DIA./LENGTH	STANDARD CHEVY #	"H" STYLE #	*CRATE MOTOR #	PRICE	CHEVY 18° #	PRICE
1 1/2" - 1 5/8"	3" x 8"	134V	134VH	----	309.95	----	----
1 5/8"	3" x 8"	135	135H	135CM	249.95	----	----
1 5/8" - 1 3/4"	3 1/2" x 8"	135V	135VH	135VCM	299.95	----	----
1 5/8" - 1 3/4"	3" x 8"	135V-3	135VH-3	135VCM-3	299.95	----	----
1 3/4"	3 1/2" x 8"	136	136H	136CM	249.95	----	----
1 3/4" - 1 7/8"	3 1/2" x 9"	136V	136VH	136VCM	309.95	136V18	369.95
1 3/4" - 2"	3 1/2" x 9"	136V2	136V2H	----	329.95	136V2-18	389.95
1 3/4" - 1 7/8" - 2"	3 1/2" x 9"	136V3	136V3H	----	369.95	136V3-18	429.95

Fits Jerico Trans.

Available for GARC chassis

* = 604 Crate Motor

H-style fits Howe, Port City and stock clip cars.
 (Different #7 cylinder)



H Style

For extension (elbow) applications see page 44-45

Bolts and Gaskets included



Conventional Crossover Headers (cont.)

CNC laser cut flanges available to fit 18° Brodix spread port,
 and Spread Port.

Dart, Pontiac 867 and Stahl pattern heads.

SB Chevy (will not fit lefthander fab chassis)

TUBE DIAMETER	COLLECTOR DIA./LENGTH	STANDARD CHEVY #	*CRATE MOTOR #	PRICE	CHEVY 18° #	PRICE
1 1/2" - 1 5/8"	3" x 8"	144V	-----	309.95	-----	-----
1 5/8"	3" x 8"	145	145CM	249.95	-----	-----
1 5/8" - 1 3/4"	3 1/2" x 8"	145V	145VCM	299.95	-----	-----
1 5/8" - 1 3/4"	3" x 8"	145V-3	145VCM-3	299.95	-----	-----
1 3/4"	3 1/2" x 8"	146	146CM	249.95	-----	-----
1 3/4" - 1 7/8"	3 1/2" x 9"	146V	146VCM	309.95	146V18	369.95
1 3/4" - 1 7/8" - 2"	3 1/2" x 9"	146V3	-----	369.95	146V3-18	429.95

* = 604 Crate Motor

Mopar (will not fit lefthander fab chassis)

TUBE DIAMETER	COLLECTOR DIA./LENGTH	STANDARD MOPAR #	W2 #	PRICE
1 5/8"	3" x 8"	445	445W2	319.95
1 5/8" - 1 3/4"	3 1/2" x 8"	445V	445VW2	369.95
1 5/8" - 1 3/4"	3" x 8"	445V-3	445VW2-3	369.95
1 3/4"	3 1/2" x 8"	446	*446W2	319.95
1 3/4" - 1 7/8"	3 1/2" x 9"	446V	*446VW2	379.95

*W-2 Flanges, specify 4" or 4 3/4" spread on center bolts.

For extension (elbow) applications see page 44-45



Mopar

TUBE DIAMETER	COLLECTOR DIA./LENGTH	STANDARD MOPAR #	W2 #	PRICE
1 5/8"	3" x 8"	435	435W2	319.95
1 5/8" - 1 3/4"	3 1/2" x 8"	435V	435VW2	369.95
1 5/8" - 1 3/4"	3" x 8"	435V-3	435VW2-3	369.95
1 3/4"	3 1/2" x 8"	436	*436W2	319.95
1 3/4" - 1 7/8"	3 1/2" x 9"	436V	*436VW2	379.95

For extension (elbow) applications see page 44-45

*W-2 Flanges, specify 4" or 4 3/4" spread on center bolts.

Schoenfeld headers are not legal for sale or use on any pollution controlled vehicle intended for street or highway use.

Tractor/Derby
 Crossover
 Drag 4 Cyl.
 Collectors
 180° Crossover
 Stock Clip
 Flanges/Gaskets
 Street Stock
 U & J Bends
 Chassis
 X & Y Pipes
 IMCA Mod.
 Turnouts & Extensions
 Dirt Late Model
 Sprint
 Misc.
 Midget
 Elbow Applications
 Chassis Applications
 Mufflers

Ford Crossover

Ford (*Fits wide Dart bolt pattern and Sportsman "N" head)

TUBE DIAMETER	COLLECTOR DIA./LENGTH	289-302-351 WINDSOR #	DART/"N" SPORTSMAN #	CRATE MOTOR #	PRICE
1 5/8"	3" x 8"	335	*335N	335CM	299.95
1 5/8" - 1 3/4"	3 1/2" x 8"	335V	*335VN	335VCM	349.95
1 5/8" - 1 3/4"	3" x 8"	335V-3	*335VN-3	335VCM-3	349.95
1 3/4"	3 1/2" x 9"	336	*336N	336CM	309.95
1 3/4" - 1 7/8"	3 1/2" x 9"	336V	*336VN	336VCM	369.95



Available for Edelbrock
CM Fits Z304 Headed Crate motor

Bolts and Gaskets included

Chevy 180° Crossover



Exits thru lower right door.
 Uses 48" extension.

TUBE DIAMETER	COLLECTOR DIA./LENGTH	STANDARD CHEVY #	PRICE
1 5/8"	3" x 8"	179-1	259.95
1 5/8" - 1 3/4"	3 1/2" x 9"	179V-1	309.95
1 3/4"	3 1/2" x 9"	180-1	259.95

For extension (elbow) applications see page 44-45

Bolts and Gaskets included

Chevy 180° Crossover



Exits thru fender behind right front tire.
 Uses 36" extension.

TUBE DIAMETER	COLLECTOR DIA./LENGTH	STANDARD CHEVY #	PRICE
1 5/8"	3" x 8"	179-2	269.95
1 5/8" - 1 3/4"	3 1/2" x 9"	179V-2	319.95
1 3/4"	3 1/2" x 9"	180-2	269.95

For extension (elbow) applications see page 44-45

Bolts and Gaskets included

SB Chevy 180° Crossover Header



TUBE DIAMETER	COLLECTOR DIA./LENGTH	STANDARD CHEVY #	PRICE	SPREAD PORT #	PRICE
1 5/8" - 1 3/4"	3 1/2" x 9"	D179V	369.95	----	----
1 5/8" - 1 7/8"	3 1/2" x 9"	D179V2	379.95	----	----
1 3/4"	3 1/2" x 9"	D180	309.95	----	----
1 3/4" - 1 7/8"	3 1/2" x 9"	D180V	369.95	D180VSP	429.95

Bolts and Gaskets included
 Will not fit Power Glide trans.

For extension (elbow) applications see page 44-45

Ceramic coating add \$275.00

Fits Howe, Lefthander, Port City, Etc. chassis type offset cars as well as earlier straight up models.

TUBE DIAMETER	COLLECTOR DIA./LENGTH	STANDARD CHEVY #	PRICE	SPREAD PORT #	PRICE
1 5/8" - 1 3/4"	3 1/2" x 9"	H179V	369.95	----	----
1 5/8" - 1 7/8"	3 1/2" x 9"	H179V2	379.95	----	----
1 3/4"	3 1/2" x 9"	H180	309.95	----	----
1 3/4" - 1 7/8"	3 1/2" x 9"	H180V	369.95	H180VSP	429.95



Bolts and Gaskets included
 Will not fit Power Glide trans.

For extension (elbow) applications see page 44-45

Ford Tri Y Crossover



TUBE DIAMETER	COLLECTOR DIA.	289-302-351 WINDSOR #	DART/"N" SPORTSMAN #	EDLE/MCGUN #	PRICE
1 5/8" - 1 3/4"	3"	335VY	335VYN	335VYE	759.95
1 3/4" - 1 7/8" - 2"	3 1/2"	336V3Y	336V3YN	336V3YE	809.95

Comes With 5/16" Flange



For extension (elbow) applications see page 44-45

Bolts and Gaskets included

Chevy Stock Clip Header

Chevy Fits straight or angle plug heads.



Spread port Available
 Exits over frame rail. (Both sides)

TUBE DIAMETER	COLLECTOR DIA./LENGTH	STANDARD CHEVY #	*CRATE MOTOR #	PRICE
1 5/8"	3" x 8"	155	-----	189.95
1 5/8" - 1 3/4"	3 1/2" x 8"	155V	155VCM	239.95
1 5/8" - 1 3/4"	3" x 8"	155V-3	155VCM-3	239.95
1 3/4"	3 1/2" x 8"	156	156CM	189.95
1 3/4"	3" x 8"	156-3	-----	189.95
1 3/4" - 1 7/8"	3 1/2" x 9"	156V	156VCM	259.95

* = 604 Crate Motor

Chevy Fits straight or angle plug heads.

TUBE DIAMETER	COLLECTOR DIA./LENGTH	STANDARD CHEVY #	PRICE	SPREAD PORT #	PRICE
1 5/8"	3" x 8"	125	209.95	-----	-----
1 5/8" - 1 3/4"	3 1/2" x 8"	125V	259.95	-----	-----
1 5/8" - 1 3/4"	3" x 8"	125V-3	259.95	-----	-----
1 3/4"	3 1/2" x 8"	126	209.95	-----	-----
1 3/4"	3" x 8"	126-3	209.95	-----	-----
1 3/4" - 1 7/8"	3 1/2" x 9"	126V	269.95	126VSP	329.95

Exits over frame rail. (Both sides)

Will not fit with stock upper control arms.
 Engine must be moved back.

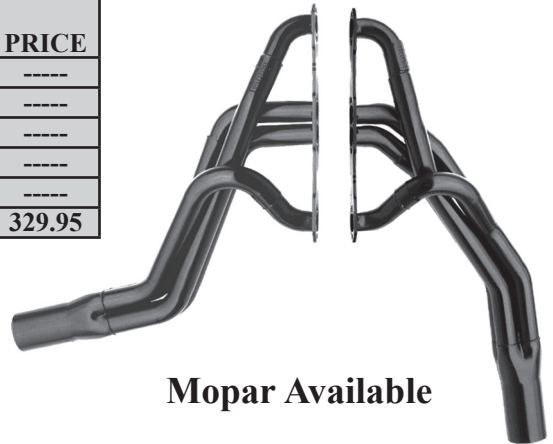

Mopar Available

Camaro Stock Clip



Must use stock height springs.

* = 604 Crate Motor

TUBE DIAMETER	COLL. DIA./LNTH	STANDARD PORT #	*CRATE MOTOR #	PRICE
1 5/8"	3" x 8"	103	103CM	209.95
1 5/8" - 1 3/4"	3" x 8"	103V-3	103VCM-3	259.95
1 5/8" - 1 3/4"	3 1/2" x 8"	103V	103VCM	259.95
1 3/4"	3" x 8"	104-3	104CM-3	209.95
1 3/4"	3 1/2" x 8"	104	104CM	209.95
1 3/4" - 1 7/8"	3 1/2" x 9"	104V	104VCM	269.95

Metric Stock Clip

TUBE DIAMETER	COLL. DIA./LNTH	STANDARD CHEVY #	*CRATE MOTOR #	PRICE
1 5/8"	3" x 8"	107	107CM	209.95
1 5/8" - 1 3/4"	3" x 8"	107V-3	107VCM-3	259.95
1 5/8" - 1 3/4"	3 1/2" x 8"	107V	-----	259.95
1 3/4"	3" x 8"	108-3	108CM-3	209.95
1 3/4"	3 1/2" x 8"	108	108CM	209.95
1 3/4" - 1 7/8"	3 1/2" x 9"	108V	108VCM	269.95
1 7/8"	3 1/2" x 9"	109	-----	309.95



Must use stock height springs.

* = 604 Crate Motor

Ford Stock Clip Header

Ford

TUBE DIAMETER	COLLECTOR DIA./LENGTH	WINDSOR 289-302-351	DART/ "N" SPORTSMAN	PRICE
1 5/8" - 1 3/4"	3 1/2" x 8"	355V	*355VN	309.95
1 3/4"	3 1/2" x 8"	356	*356N	279.95
1 3/4" - 1 7/8"	3 1/2" x 9"	356V	*356VN	319.95

*Fits the wide Dart Bolt Pattern and Sportsman "N" head
 (Available for Edelbrock)

Exits over frame rail. (Both sides)

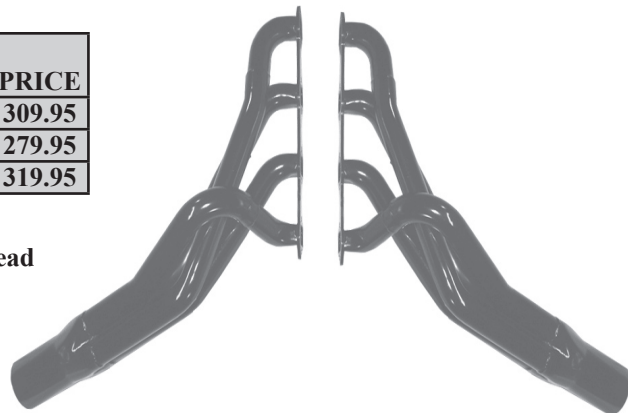

NEW! Chevy Stock Car **IMCA - UMP** **NEW!**

No clearance issues with oil filter, spark plugs, starter, kick out oil pan, rear mounts, valve covers. Clears firewall that is minimum 7" from back of block.

Exits inside frame rail

Fits Harris, Jet, Victory

TUBE DIAMETER	COLLECTOR DIA./LENGTH	STANDARD CHEVY #	*CRATE MOTOR #	PRICE
1 5/8"	3" x 8"	195	195CM	209.95
1 5/8" - 1 3/4"	3" x 8"	195V-3	195VCM-3	259.95
1 3/4"	3" x 8"	196-3	196CM-3	209.95

Bolts and Gaskets included

80 degree elbow available - part # 3081

* = 604 Crate Motor

Exits outside frame rail

TUBE DIAMETER	COLLECTOR DIA./LENGTH	STANDARD CHEVY #	*CRATE MOTOR #	PRICE
1 5/8"	3" x 8"	197	197CM	209.95
1 5/8" - 1 3/4"	3" x 8"	197V-3	197VCM-3	259.95
1 3/4"	3" x 8"	198-3	198CM-3	209.95

Bolts and Gaskets included

Schoenfeld headers are not legal for sale or use on any pollution controlled vehicle intended for street or highway use.

Chevy Street Stock

1972 - 1987 Chevy Malibu, Monte Carlo, Pontiac Grand Prix, Olds Cutlass, Buick Regal.
 Also Camaro, 70 - 81

Can use solid side and rear mounts.

Will Fit straight or angle plug heads.

Will not clear stock manual clutch linkage ball located behind the #7 cylinder.

Will not fit with some mini starters.

Will not fit some kick-out oil pans.

Must use short oil filter.

TUBE DIAMETER	COLLECTOR DIA./LENGTH	STANDARD CHEVY #	*CRATE MOTOR #	PRICE	SPREAD PORT #	CHEVY 18° #	PRICE
1 1/2" - 1 5/8"	3" x 8"	184V	----	239.95	----	----	----
1 5/8"	3" x 8"	185	185CM	179.95	----	----	----
1 5/8" - 1 3/4"	3" x 8"	185V	185VCM	229.95	----	----	----
1 3/4"	3 1/2" x 8"	186	186CM	179.95	----	----	----
1 3/4"	3" x 8"	186-3	186CM-3	179.95	----	----	----
1 3/4" - 1 7/8"	3 1/2" x 9"	186V	186VCM	299.95	186VSP	186V18	359.95
1 7/8"	3 1/2" x 9"	187	----	359.95	187SP	187-18	419.95



Oil Filters Such As:
 Wix 51069 - AC PF24

Designed to fit with engine in stock location.

* = 604 Crate Motor

Ceramic Coating add \$275.00

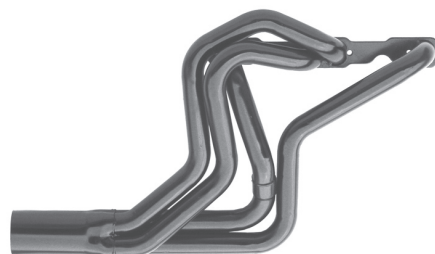

1972 - 1987 Chevy Malibu, Monte Carlo,
 Pontiac Grand Prix, Olds Cutlass, Buick Regal.
 Also Camaro 70 - 81.

Clears side and rear engine mounts.

Will Fit straight or angle plug heads.

Will clear stock manual clutch linkage ball.



Must use short oil filter.

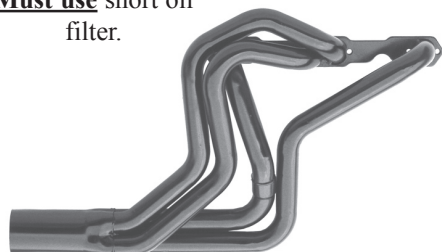

Spread port & 18° available for 1 3/4" & 1 7/8"

TUBE DIAMETER	COLLECTOR DIA./LENGTH	STANDARD CHEVY #	*CRATE MOTOR #	PRICE
1 1/2" - 1 5/8"	3" x 8"	184VM	----	239.95
1 5/8"	3" x 8"	185M	185MCM	179.95
1 5/8" - 1 3/4"	3" x 8"	185VM	185VMCM	229.95
1 3/4"	3 1/2" x 8"	186M	186MCM	179.95
1 3/4"	3" x 8"	186M-3	186MCM-3	179.95
1 3/4" - 1 7/8"	3 1/2" x 9"	186VM	186VMCM	279.95
1 7/8"	3 1/2" x 9"	187M	----	359.95

Designed to fit with engine in stock location.

* = 604 Crate Motor

479-474-7529
 Fax # 479-474-2249
 Van Buren, AR
 www.SchoenfeldHeaders.com



Street Stock

**Camaro 70 - 81, Chevy II, Nova 75-79
 Chevelle 64 - 77, Monte Carlo 72 - 77**

TUBE DIAMETER	COLLECTOR DIA./LENGTH	STANDARD CHEVY #	PRICE
1 5/8"	3" x 8"	165	179.95
1 5/8" - 1 3/4"	3" x 8"	165V	229.95
1 5/8" - 1 3/4" - 1 7/8"	3 1/2" x 9"	165V3	299.95
1 3/4"	3 1/2" x 8"	166	179.95
1 3/4"	3" x 8"	166-3	179.95

Conventional Style Headers for Car with Engines in Stock Location or engine set back.

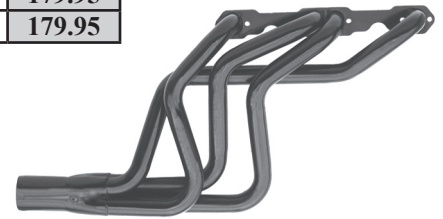
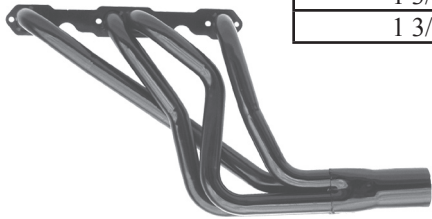

Will not fit angle plug heads.
Will not clear rear mounts.

Camaro 70-81, Monte Carlo 72-77, Nova 75-79. Will Not Fit Chevelle

TUBE DIAMETER	COLLECTOR DIA./LENGTH	STANDARD CHEVY #	*CRATE MOTOR #	PRICE	SPREAD PORT #	PRICE
1 5/8"	3" x 8"	165A	165ACM	179.95	----	----
1 5/8" - 1 3/4"	3" x 8"	165VA	165VACM	229.95	----	----
1 5/8" - 1 3/4" - 1 7/8"	3 1/2" x 9"	165V3A	165V3ACM	299.95	----	----
1 3/4"	3 1/2" x 8"	166A	166ACM	179.95	----	----
1 3/4"	3" x 8"	166A-3	166ACM-3	179.95	----	----
1 3/4" - 1 7/8"	3 1/2" x 9"	166VA	166VACM	299.95	166VASP	359.95
1 7/8"	3 1/2" x 9"	167A	-----	359.95	167ASP	419.95

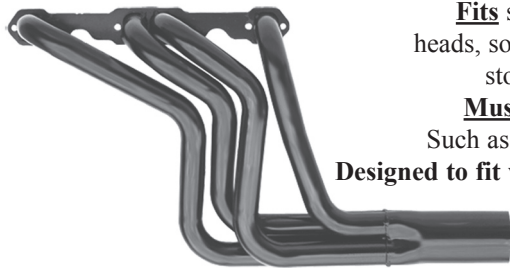

Fits straight or angle plug heads, solid side and rear mounts, stock clutch linkage.
Must use short oil filter.
 Such as Wix 51069 - AC PF24
 Designed to fit with engine in stock location.

* = 604 Crate Motor

Ford Street Stock / Truck

Designed to fit Camaro, Intermediate GM, Front Clips.

TUBE DIAMETER	COLLECTOR DIA./LENGTH	WINDSOR 289-302-351	CRATE MOTOR	DART/ "N" SPORTSMAN	PRICE
1 5/8"	3" x 8"	385	385CM	*385N	239.95
1 5/8" - 1 3/4"	3" x 8"	385V	385VCM	*385VN	289.95
1 3/4"	3 1/2" x 8"	386	386CM	*386N	239.95

*Fits the wide Dart Bolt Pattern and Sportsman "N" head
 (Available for Edelbrock)
 Fits Ford Trucks 1967-1972

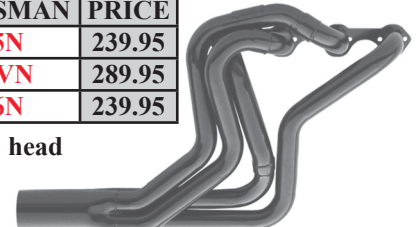
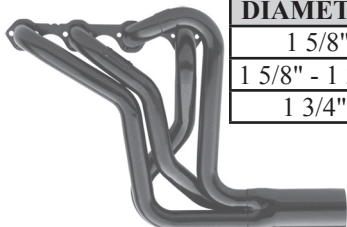

Tractor/Derby
 Dirt Mod.
 Crossover
 Drag 4 Cyl.
 Collectors
 180° Crossover
 Flanges/Gaskets
 Stock Clip
 Street Stock
 U & J Bends
 Chassis
 IMCA Mod.
 Turnouts & Extensions
 X & Y Pipes
 Sprint
 Misc.
 Midget
 Elbow Applications
 Chassis Applications
 Mufflers

New! Chevy Drag "Street Class"

Camaro 1967-1969

TUBE DIAMETER	COLLECTOR DIA./LENGTH	STANDARD CHEVY #	PRICE
1 5/8"	3" x 8"	115	279.95
1 5/8" - 1 3/4"	3 1/2" x 8"	115V	319.95
1 5/8" - 1 3/4"	3" x 8"	115V-3	319.95
1 3/4"	3 1/2" x 8"	116	279.95
1 3/4"	3" x 8"	116-3	279.95
1 3/4" x 1 7/8"	3 1/2" x 9"	116V	349.95

Fits Motor in stock location, straight plug heads, stock clutch linkage.



Chevy Chassis Headers

Fits older Bullitt, GRT, Howe, NASCAR LMS, Shaw, and most IMCA Modifieds.
 Fits angle plug or straight plug heads, #1 spark plug needs to be at least 1" behind ball joint.

TUBE DIAMETER	COLLECTOR DIA./LENGTH	STANDARD CHEVY #	CRATE MOTOR #	PRICE	SPREAD PORT #	PRICE
1 5/8"	3" x 8"	*151	*151CM	159.95	----	----
1 5/8" - 1 3/4"	3 1/2" x 8"	151V	151VCM	219.95	----	----
1 3/4"	3" x 8"	152-3	152CM-3	179.95	----	----
1 3/4"	3 1/2" x 8"	152	152CM	169.95	----	----
1 3/4" - 1 7/8"	3 1/2" x 9"	152V	152VCM	239.95	152VSP	319.95
1 7/8"	3 1/2" x 9"	153	----	199.95	153SP	379.95

*NASCAR LMS Legal

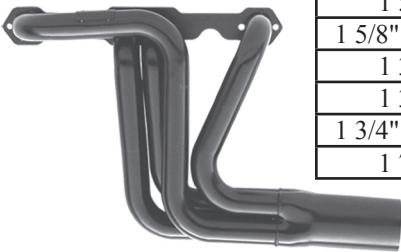

151EL - 30" Primaries. Closer to equal length than 151 style.

TUBE DIAMETER	COLLECTOR DIA./LENGTH	STANDARD CHEVY #	CRATE MOTOR #	PRICE
1 5/8"	3" x 8"	*151E	*151ECM	159.95
1 5/8"	3" x 8"	*151EL	*151ELCM	189.95
1 5/8" - 1 3/4"	3 1/2" x 8"	151EV	----	219.95
1 3/4"	3" x 8"	152E-3	152ECM-3	179.95
1 3/4"	3 1/2" x 8"	152E	152ECM	179.95
1 3/4" - 1 7/8"	3 1/2" x 9"	152EV	152EVCM	239.95

*NASCAR LMS Legal

Ford Available
151E

151EL

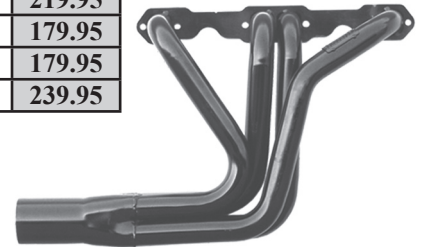
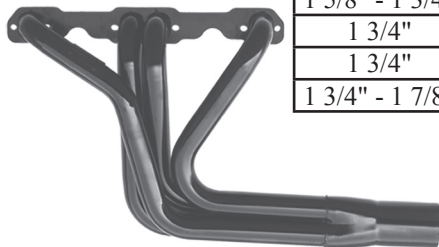

Zoomie Grassburner

Fits Chevy Late Model, IMCA type modified, Camaro, Chevelle, etc.

TUBE SIZE	STANDARD CHEVY #	PRICE
1 3/4"	130	119.95

Fits Straight or Angle plug heads.





IMCA Modified

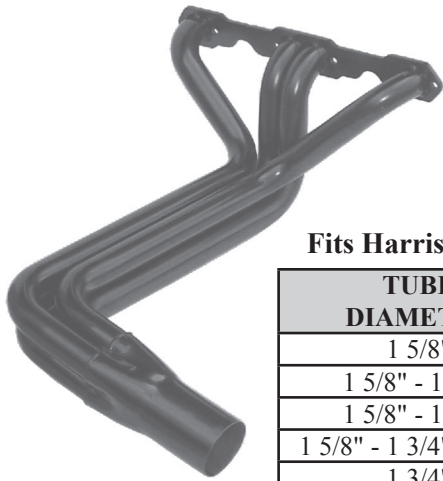

Fits Harris, Skyrocket, Victory

TUBE DIAMETER	COLLECTOR DIA./LENGTH	STANDARD CHEVY #	*CRATE MOTOR #	PRICE
1 5/8"	3" x 8"	11619H	11619HCM	209.95
1 5/8" - 1 3/4"	3 1/2" x 8"	1161V9H	1161V9HCM	259.95
1 5/8" - 1 3/4"	3" x 8"	1161V9H-3	1161V9HCM-3	259.95
1 5/8" - 1 3/4" - 1 7/8"	3" x 9"	1161V39H-3	1161V39HCM-3	309.95
1 3/4"	3 1/2" x 8"	11629H	11629HCM	209.95
1 3/4" - 1 7/8"	3 1/2" x 8"	1162V9H	1162V9HCM	269.95

Bolts and Gaskets included

* = 604 Crate Motor

IMCA Modified Mid-Length Primary Design

Chevy

Fits BMS, Dirtworks, GRT, Harris, Hoffman, Jet Racing, Larry Shaw. (Pierce uses 1106A style)

TUBE DIAMETER	COLLECTOR DIA./LENGTH	STANDARD CHEVY #	*CRATE MOTOR #	PRICE	SPREAD PORT/D.N #	CHEVY 18° #	PRICE
1 5/8"	3" x 8"	1105	1105CM	209.95	----	----	----
1 5/8" - 1 3/4"	3 1/2" x 8"	1105V	1105VCM	259.95	----	----	----
1 5/8" - 1 3/4"	3" x 8"	1105V-3	1105VCM-3	259.95	----	----	----
1 3/4"	3 1/2" x 8"	1106	1106CM	209.95	1106SP	----	269.95
1 3/4" - 1 7/8"	3 1/2" x 9"	1106V	1106VCM	269.95	1106VSP	1106V18	329.95

* = 604 Crate Motor

Smoother
Power Band

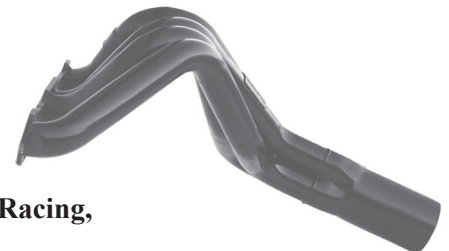

Ford

Fits BMS, Dirtworks, GRT, Harris, Hoffman, Jet Racing, Larry Shaw.

TUBE DIAMETER	COLLECTOR DIA./LENGTH	WINDSOR 289-302-351 #	DART "N" #	PRICE
1 5/8"	3" x 8"	3105	3105N	249.95
1 5/8" - 1 3/4"	3 1/2" x 8"	3105V	3105VN	309.95
1 5/8" - 1 3/4"	3" x 8"	3105V-3	3105VN-3	309.95
1 3/4"	3 1/2" x 8"	3106	3106N	259.95
1 3/4" - 1 7/8"	3 1/2" x 9"	3106V	3106VN	319.95



479-474-7529
 Fax # 479-474-2249
 Van Buren, AR
 www.SchoenfeldHeaders.com

IMCA Modified Long-Tube Design

Fits BMS, Dirtworks, Hoffman, Hot, Jet, KMOD, Bob Pierce, Pro, Quick, Sardeson, Smiley's, Victory.

TUBE DIAMETER	COLLECTOR DIA./LENGTH	STANDARD CHEVY #	*CRATE MOTOR #	PRICE	SPREAD PORT #	CHEVY 18° #	PRICE
1 5/8"	3" x 8"	1185	1185CM	209.95	----	----	----
1 5/8" - 1 3/4"	3 1/2" x 8"	1185V	1185VCM	259.95	----	----	----
1 5/8" - 1 3/4"	3" x 8"	1185V-3	1185VCM-3	259.95	----	----	----
1 5/8" - 1 3/4" - 1 7/8"	3" x 9"	1185V3-3	1185V3CM-3	309.95	----	----	----
1 3/4"	3 1/2" x 8"	1186	1186CM	209.95	1186SP	----	269.95
1 3/4" - 1 7/8"	3 1/2" x 9"	1186V	1186VCM	269.95	1186VSP	1186V18	329.95

Available in LS1-LS7
 Ceramic Coating, Add \$275.00
 Bolts and Gaskets included
 * = 604 Crate Motor

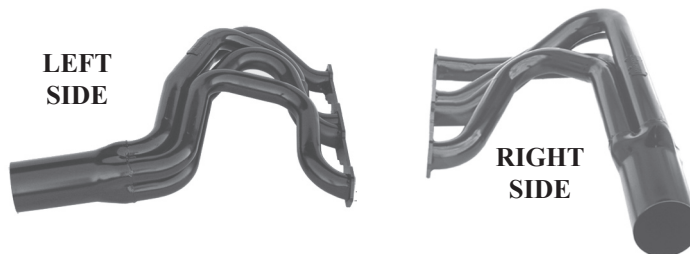

Fits BMS, Bob Pierce, Dirtworks, Harris, Hoffman, Hot, Hughes, Jet, Larry Shaw, Lightning, Lou Fegers, M&M, Pro, Sardeson.

TUBE DIAMETER	COLLECTOR DIA./LENGTH	STANDARD CHEVY #	PRICE	SPREAD PORT #	*CRATE MOTOR #	PRICE
1 5/8"	3" x 8"	1175	219.95	----	----	----
1 5/8" - 1 3/4"	3 1/2" x 8"	1175V	269.95	----	1175VCM	269.95
1 5/8" - 1 3/4"	3" x 8"	1175V-3	269.95	----	1175VCM-3	269.95
1 3/4"	3 1/2" x 8"	1176	219.95	----	----	----
1 3/4" - 1 7/8"	3 1/2" x 9"	1176V	279.95	1176VSP	----	339.95
1 7/8"	3 1/2" x 9"	1177	249.95	1177SP	----	309.95

Ceramic Coating, Add \$275.00
 Chevy 18° Available
 Bolts and Gaskets included
 * = 604 Crate Motor

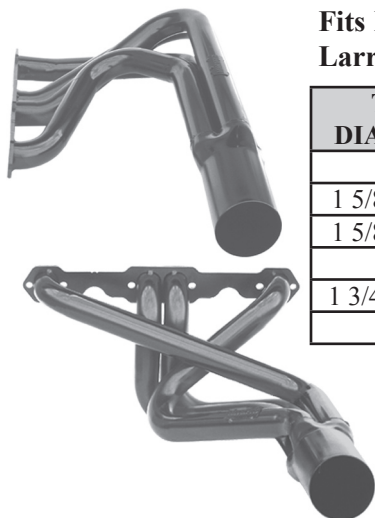

Small Block Chevy

Fits most chassis'

TUBE DIAMETER	COLLECTOR DIA./LENGTH	STANDARD CHEVY #	*CRATE MOTOR #	PRICE
1 5/8"	3" x 8"	171	171CM	189.95
1 5/8" - 1 3/4"	3" x 8"	171V-3	171VCM-3	239.95
1 3/4"	3 1/2" x 8"	172	----	189.95
1 3/4" - 1 7/8"	3 1/2" x 9"	172V	----	249.95
1 7/8"	3 1/2" x 9"	173	----	239.95

Bolts and Gaskets included
 * = 604 Crate Motor



Tractor/Drumby
 4 Cyl. Drag
 Collector
 180° Crossover
 Flanges/Gaskets
 Stock Clip
 Street Stock
 U & J Bends
 Chassis
 X & Y Pipes
 Turnouts & Extensions
 Misc.
 Midget
 Chassis Applications
 Mufflers



IMCA Modified Long-Tube Design

Longer primaries for maximum torque and horsepower

Fits Harris, Hoffman chassis'

TUBE DIAMETER	COLLECTOR DIA./LENGTH	STANDARD CHEVY #	*CRATE MOTOR #	PRICE
1 5/8"	3" x 8"	1101	1101CM	209.95
1 5/8" - 1 3/4"	3" x 8"	1101V-3	1101VCM-3	259.95
1 5/8" - 1 3/4" - 1 7/8"	3" x 8"	1101V3-3	1101V3CM-3	309.95
1 3/4"	3 1/2" x 8"	1102	1102CM	209.95
1 3/4" - 1 7/8"	3 1/2" x 9"	1102V	1102VCM	259.95



Bolts and Gaskets included

* = 604 Crate Motor



IMCA Modified Long-Tube Design

Fits Larry Shaw - Part # 1155 Fits Victory chassis'

TUBE DIAMETER	COLLECTOR DIA./LENGTH	STANDARD CHEVY #	*CRATE MOTOR #	PRICE
1 5/8"	3" x 8"	1155L	1155LCM	209.95
1 5/8" - 1 3/4"	3" x 8"	1155LV-3	1155LVCM-3	259.95
1 5/8" - 1 3/4" - 1 7/8"	3" x 9"	1155LV3-3	1155LV3CM-3	309.95
1 3/4"	3 1/2" x 8"	1156L	1156LCM	209.95
1 3/4" - 1 7/8"	3 1/2" x 9"	1156LV	1156LVCM	259.95

NEW!

NEW!



Bolts and Gaskets included

* = 604 Crate Motor



Schoenfeld headers are not legal for sale or use on any pollution controlled vehicle intended for street or highway use.

Chassis Applications | Midget | Sprint | Dirt Late Model | IMCA Mod. | Chassis | Street Stock | Stock Clip | 180° Crossover | Crossover | Tractor/Derby | Mufflers | Elbow Applications | Misc. | Turnouts & Extensions | X & Y Pipes | U & J Bends | Flanges/Gaskets | Collectors | Drag | 4 Cyl. | Dirt Mod.

IMCA Modified Headers

Left Side Collectors

Right Side Collectors

Header Numbering System

ENGINE TYPE	HEADER STYLE	TUBE DIAMETER	LEFT COLL. STYLE	RIGHT COLL. STYLE

161-68

For collector part number, see page 42

Small Block Chevy

TUBE DIAMETER	COLLECTOR DIA./LENGTH	FLANGE	L-STYLE 3 R-STYLE 8	L-STYLE 6 R-STYLE 8	L-STYLE 9 R-STYLE 8	L-STYLE 9H R-STYLE 8	PRICE
1 1/2" - 1 5/8"	3" x 8"	STANDARD	160-38	160-68	160-98	160-98H	199.95
1 5/8" - 1 3/4"	3" x 8"	STANDARD	161-38	161-68	161-98	161-98H	179.95
1 3/4" - 1 7/8"	3 1/2" x 9"	STANDARD	162-38	162-68	162-98	162-98H	229.95
1 3/4" - 1 7/8"	3 1/2" x 9"	SPRD PORT	162-38SP	162-68SP	162-98SP	162-98HSP	299.95
1 3/4" - 1 7/8"	3 1/2" x 9"	18° CHEVY	162-38-18	162-68-18	162-98-18	162-98H-18	299.95
1 7/8" - 2"	3 1/2" x 9"	STANDARD	163-38	163-68	163-98	163-98H	269.95

Bolts and Gaskets included

Small Block Ford

TUBE DIAMETER	COLLECTOR DIA./LENGTH	FLANGE	L-STYLE 3 R-STYLE 8	L-STYLE 6 R-STYLE 8	L-STYLE 9 R-STYLE 8	L-STYLE 9H R-STYLE 8	PRICE
1 5/8" - 1 3/4"	3" x 8"	WINDSOR	361-38	361-68	361-98	361-98H	269.95
1 3/4" - 1 7/8"	3 1/2" x 9"	WINDSOR	362-38	362-68	362-98	362-98H	279.95
1 5/8" - 1 3/4"	3" x 8"	*DART/"N"	*361-38N	*361-68N	*361-98N	*361-98HN	269.95
1 3/4" - 1 7/8"	3 1/2" x 9"	*DART/"N"	*362-38N	*362-68N	*362-98N	*362-98HN	279.95
1 3/4" - 1 7/8"	3 1/2" x 9"	CLEVELAND	562-38	562-68	562-98	562-98H	299.95
1 3/4" - 1 7/8"	3 1/2" x 9"	SVO (ALUM.)	662-38	662-68	662-98	662-98H	299.95

Specify for 4 barrel Cleveland Flange

*Fits the wide Dart bolt pattern and Sportsman "N" head

Available for Edelbrock

www.SchoenfeldHeaders.com



IMCA Modified Headers

Small Block Chevy

TUBE DIAMETER	COLLECTOR DIA./LENGTH	STANDARD CHEVY #	*CRATE MOTOR #	PRICE	SPREAD PORT #	CHEVY 18° #	PRICE
1 1/2"	3" x 8"	160	----	179.95	----	----	----
1 5/8"	3" x 8"	161	161CM	159.95	----	----	----
1 5/8" - 1 3/4"	3" x 8"	161V-3	161VCM-3	209.95	----	----	----
1 3/4"	3 1/2" x 8"	162	162CM	159.95	----	----	----
1 7/8"	3 1/2" x 9"	163	----	249.95	163SP	163-18	309.95

Ceramic Coating add \$275.00
 Bolts and Gaskets included
 * = 604 Crate Motor



Small Block Ford

TUBE DIAMETER	COLLECTOR DIA./LENGTH	WINDSOR #	DART/"N" SPORTSMAN #	PRICE
1 5/8"	3" x 8"	361	361N	199.95
1 3/4"	3 1/2" x 8"	362	362N	209.95

(Available for Edelbrock)

TUBE DIAMETER	COLLECTOR DIA./LENGTH	CLEVELAND 2 BARREL #	CLEVELAND 4 BARREL #	PRICE
1 3/4"	3 1/2" x 8"	562	----	279.95
1 3/4"	3 1/2" x 8"	----	562-4B	309.95

Does not come with gasket.



New Design! IMCA Long Tube

Fits Victory Chassis

TUBE DIAMETER	COLLECTOR DIA./LENGTH	STANDARD CHEVY #	*CRATE MOTOR #	PRICE
1 5/8"	3" x 8"	1115	1115CM	209.95
1 5/8" - 1 3/4"	3 1/2" x 8"	1115V	1115VCM	269.95
1 5/8" - 1 3/4"	3" x 8"	1115V-3	1115VCM-3	269.95
1 5/8" - 1 3/4" - 1 7/8"	3" x 9"	1115V3-3	1115V3CM-3	329.95
1 3/4"	3 1/2" x 8"	1116	1116CM	209.95
1 3/4" - 1 7/8"	3 1/2" x 9"	1116V	1116VCM	269.95

Bolts and Gaskets included
 * = 604 Crate Motor

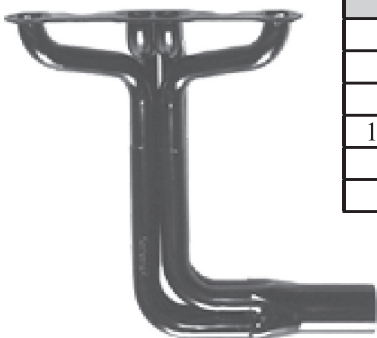

Chassis Applications | Midget Sprint | Dirt Late Model | IMCA Mod. | Chassis | Street Stock | Stock Clip | 180° Crossover | Crossover | Tractor/Derby | Mufflers | Elbow Applications | Misc. | Turnouts & Extensions | X & Y Pipes | U & J Bends | Flanges/Gaskets | Collectors | Drag | 4 Cyl. | Dirt Mod.

Ford IMCA Modified Long-Tube Design

Longer primaries for maximum torque and horsepower

Fits Dirtworks and most other Chassis

TUBE DIAMETER	COLLECTOR DIA./LENGTH	WINDSOR #	DART/ "N" HEAD #	PRICE
1 5/8" - 1 3/4"	3 1/2" x 8"	3185V	*3185VN	309.95
1 5/8" - 1 3/4"	3" x 8"	3185V-3	*3185VN-3	309.95
1 3/4"	3 1/2" x 8"	3186	*3186N	259.95
1 3/4" - 1 7/8"	3 1/2" x 9"	3186V	*3186VN	319.95

*Fits wide Dart bolt pattern and "N" head
 Ceramic Coating, Add \$275.00

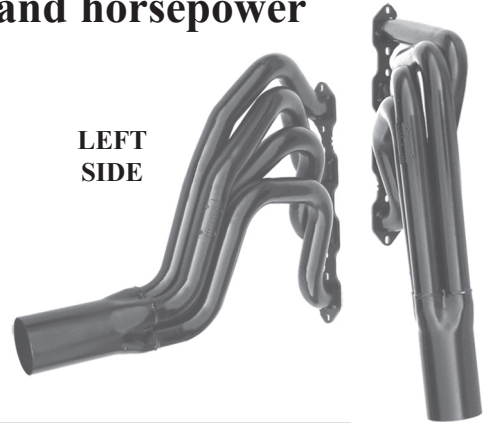

LEFT SIDE

Chevy IMCA Modified

Fits BMS, Hughes, Larry Shaw, Razor, TRE



TUBE DIAMETER	COLLECTOR DIA./LENGTH	STANDARD CHEVY #	*CRATE MOTOR #	PRICE
1 5/8"	3" x 8"	1145	1145CM	219.95
1 5/8" - 1 3/4"	3 1/2" x 8"	1145V	1145VCM	269.95
1 5/8" - 1 3/4"	3" x 8"	1145V-3	1145VCM-3	269.95
1 3/4"	3 1/2" x 8"	1146	1146CM	219.95
1 3/4" - 1 7/8"	3 1/2" x 9"	1146V	1146VCM	269.95



Available right side mirror image of left side

Bolts and Gaskets included
 Available Spread Port and 18°

* = 604 Crate Motor

IMCA Modified

Fits Hughes, J Car, Kraft, Rage, TRE

TUBE DIAMETER	COLLECTOR DIA./LENGTH	STANDARD CHEVY #	*CRATE MOTOR #	PRICE
1 5/8"	3" x 8"	1165	1165CM	229.95
1 5/8" - 1 3/4"	3 1/2" x 8"	1165V	1165VCM	279.95
1 5/8" - 1 3/4"	3" x 8"	1165V-3	1165VCM-3	279.95
1 3/4"	3 1/2" x 8"	1166	1166CM	229.95



Bolts and Gaskets included
 * = 604 Crate Motor

479-474-7529
 Fax # 479-474-2249
 Van Buren, AR
 www.SchoenfeldHeaders.com



SB Chevy Modified Tri-Y

4 Into 2 Into 1 Tube Configuration for Increased Torque

Fits Hoffman, Impressive, Bob Pierce, Victory, J Car, Harris

TUBE DIAMETER	COLLECTOR DIA.	STANDARD CHEVY #	PRICE
1 5/8" - 1 3/4"	3"	1185VY	699.95
1 3/4" - 1 7/8"	3 1/2"	1186VY	699.95

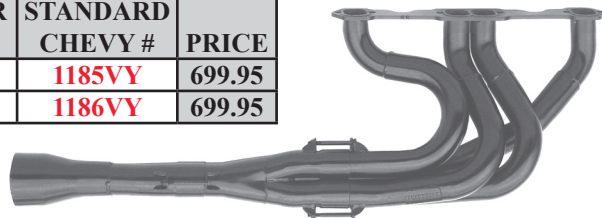
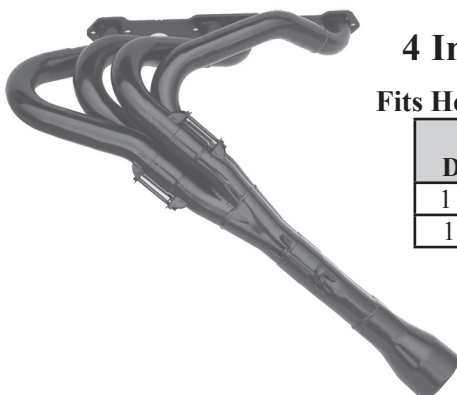

Fits Larry Shaw, J-Car, Jet, Elite

TUBE DIAMETER	COLLECTOR DIA.	STANDARD CHEVY #	PRICE
1 5/8" - 1 3/4"	3"	1195VY	699.95
1 3/4" - 1 7/8"	3 1/2"	1196VY	699.95

Spread Port & 18° Available for 1 3/4"

Comes With 5/16" Flange

SB Chevy Modified Tri-Y

4 Into 2 Into 1 Tube Configuration for Increased Torque

Fits Larry Shaw, Larry Shaw - Taylor, Harris with extended footbox.

TUBE DIAMETER	COLLECTOR DIA.	STANDARD CHEVY #	PRICE
1 5/8" - 1 3/4"	3"	1161VY	699.95
1 3/4" - 1 7/8"	3 1/2"	1162VY	699.95

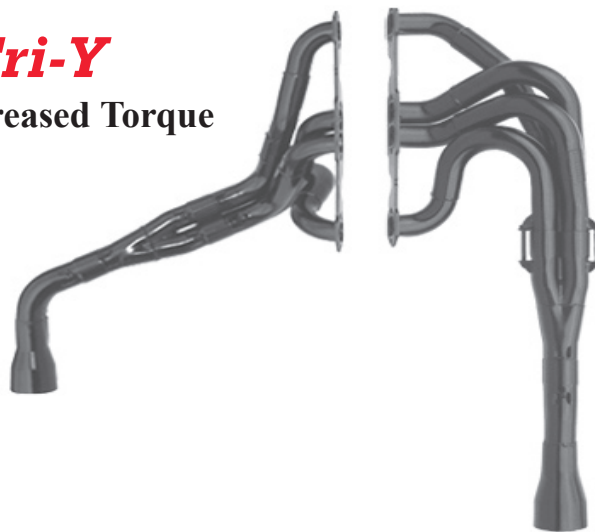

Spread Port & 18° Available for 1 3/4"

Chevy SB2 IMCA Modified Header

Fits most IMCA Modifieds

TUBE DIAMETER	COLLECTOR DIA./LENGTH	SB2 CHEVY #	PRICE
1 3/4" - 1 7/8"	3 1/2" x 9"	1186VSB2	369.95

Bolts and Gaskets included



Chassis Applications | Midget | Sprint | Dirt Late Model | IMCA Mod. | Chassis | Street Stock | Stock Clip | 180° Crossover | Crossover | Tractor/Derby | Mufflers | Elbow Applications | Misc. | Turnouts & Extensions | X & Y Pipes | U & J Bends | Flanges/Gaskets | Collectors | Drag | 4 Cyl. | Dirt Mod.

Dirt Late Model Tri - Y Headers

4 Into 2 Into 1 Tube Configuration for Increased Torque



Comes With 5/16" Flange



Rocket
Right
Side

Available in 4-7
cam swap

Fits Rocket Chassis

525 OFF-SET

Available Crate Motor

TUBE DIAMETER	COLL. DIA..	STANDARD CHEVY #	PRICE	SPREAD PORT #	13°, 15°, 16° CHEVY 18° #	PRICE	SB2 CHEVY #	PRICE
1 5/8" - 1 3/4"	3"	14152VYR	709.95	----	----	----	----	----
1 5/8" - 1 3/4" - 1 7/8"	3 1/2"	14152V3YR	759.95	----	----	----	----	----
1 3/4" - 1 7/8"	3 1/2"	14252VYR	709.95	14252VYRSP	14252VYR18	759.95	14252VYRSB2	809.95
1 3/4" - 1 7/8" - 2"	3 1/2"	14252V3YR	759.95	14252V3YRSP	14252V3YR18	809.95	14252V3YRSB2	859.95
1 7/8" - 2"	3 1/2"	14352VYR	709.95	14352VYRSP	14352VYR18	779.95	14352VYRSB2	829.95

Long Primary Dirt Late Model Tri-Y

4 Into 2 Into 1
Tube Configuration
for Increased
Torque



Fits Bob Pierce, Rayburn, Masterbilt,
Rocket-will not fit black front end.

Fits most other chassis.

Ceramic Coating add
\$275.00

Comes With 5/16" Flange

Available Brodix Spec. Head

Available Crate Motor

TUBE DIAMETER	COLL. DIA.	STANDARD CHEVY #	PRICE	SPREAD PORT #	13°, 15°, 16° CHEVY 18° #	PRICE	SB2 CHEVY #	PRICE
1 5/8" - 1 3/4"	3"	14160LVY	709.95	----	----	----	----	----
1 5/8" - 1 3/4" - 1 7/8"	3 1/2"	14160LV3Y	759.95	----	----	----	----	----
1 3/4" - 1 7/8"	3 1/2"	14260LVY	709.95	14260LVYSP	14260LVY18	759.95	14260LVYSB2	809.95
1 3/4" - 1 7/8" - 2"	3 1/2"	14260LV3Y	759.95	14260LV3YSP	14260LV3Y18	809.95	14260LV3YSB2	859.95
1 7/8" - 2"	3 1/2"	14360LVY	709.95	14360LVYSP	14360LVY18	779.95	14360LVYSB2	829.95

4-7 Cam Swap

Available Crate Motor

TUBE DIAMETER	COLL. DIA.	STANDARD CHEVY #	PRICE	SPREAD PORT #	13°, 15°, 16° CHEVY 18° #	PRICE	SB2 CHEVY #	PRICE
1 5/8" - 1 3/4"	3"	14167LVY	709.95	----	----	----	----	----
1 5/8" - 1 3/4" - 1 7/8"	3 1/2"	14167LV3Y	759.95	----	----	----	----	----
1 3/4" - 1 7/8"	3 1/2"	14267LVY	709.95	14267LVYSP	14267LVY18	759.95	14267LVYSB2	809.95
1 3/4" - 1 7/8" - 2"	3 1/2"	14267LV3Y	759.95	14267LV3YSP	14267LV3Y18	809.95	14267LV3YSB2	859.95
1 7/8" - 2"	3 1/2"	14367LVY	709.95	14367LVYSP	14367LVY18	779.95	14367LVYSB2	829.95



New Design! Dirt Late Model Long Tube

24" - Rocket, 2012 Barry Wright

26" - GRT, TNT, Bob Pierce,
 Barry Wright,
 Bernheisel, Larry Shaw,
 Mastersbuilt, Rayburn and Warrior.

I/S - From head surface to inside left collector



***Spread Port**
Available Brodix Spec Heads

TUBE DIAMETER	COLLECTOR DIA./LENGTH	STANDARD CHEVY # 24" TO I/S COLL.	STANDARD CHEVY # 26" TO I/S COLL.	STANDARD CHEVY # 28" TO I/S COLL.	PRICE
1 5/8" - 1 3/4"	3 1/2" x 8"	181-406LVG	181-606LVG	181-806LVG	319.95
1 5/8" - 1 3/4"	3" x 8"	181-406LVG-3	181-606LVG-3	181-806LVG-3	319.95
1 5/8" - 1 3/4" - 1 7/8"	3" x 8"	181-406LV3G-3	181-606LV3G-3	181-806LV3G-3	369.95
1 3/4" - 1 7/8"	3 1/2" x 9"	182-406LVG	182-606LVG	182-806LVG	319.95
1 3/4" - 1 7/8"	3 1/2" x 9"	*182-406LVGSP	*182-606LVGSP	*182-806LVGSP	379.95
1 3/4" - 1 7/8"	3" x 8"	182-406LVG-3	182-606LVG-3	182-806LVG-3	319.95
1 3/4" - 1 7/8"	3" x 8"	*182-406LVGSP-3	*182-606LVGSP-3	*182-806LVGSP-3	379.95

New Design! Dirt Late Model Crate Motor

24" - Rocket, 2012 Barry Wright

26" - GRT, TNT, Bob Pierce,
 Barry Wright,
 Bernheisel, Larry Shaw,
 Mastersbuilt, Rayburn and Warrior.

I/S - From head surface to inside left collector



TUBE DIAMETER	COLLECTOR DIA./LENGTH	*CRATE MOTOR # 24" TO I/S COLL.	*CRATE MOTOR # 26" TO I/S COLL.	*CRATE MOTOR # 28" TO I/S COLL.	PRICE
1 5/8" - 1 3/4"	3 1/2" x 8"	181-406LVGCM	181-606LVGCM	181-806LVGCM	319.95
1 5/8" - 1 3/4"	3" x 8"	181-406LVGCM-3	181-606LVGCM-3	181-806LVGCM-3	319.95
1 5/8" - 1 3/4" - 1 7/8"	3" x 8"	181-406LV3GCM-3	181-606LV3GCM-3	181-806LV3GCM-3	369.95
1 3/4" - 1 7/8"	3 1/2" x 9"	182-406LVGCM	182-606LVGCM	182-806LVGCM	319.95
1 3/4" - 1 7/8"	3" x 8"	182-406LVGCM-3	182-606LVGCM-3	182-806LVGCM-3	319.95

* = 604 Crate Motor

Chassis Applications | Midget | Sprint | Dirt Late Model | IMCA Mod. | Chassis | Street Stock | Stock Clip | 180° Crossover | Crossover | Tractor/Derby | Mufflers | Elbow Applications | Misc. | Turnouts & Extensions | X & Y Pipes | U & J Bends | Flanges/Gaskets | Collectors | Drag | 4 Cyl. | Dirt Mod.

Chevy Dirt Late Model

Fits GRT, Stinger, TNT, Bob Pierce, Barry Wright, Bullitt, Larry Shaw, Raider, Warrior and Rayburn

WILL NOT FIT GRT COMPUTER CAR



LEFT SIDE



G-RIGHT SIDE

* = 604 Crate Motor

605 OFF-SET

Available Brodix Spec. Head

TUBE DIAMETER	COLL. DIA. LENGTH	STANDARD CHEVY #	*CRATE MOTOR #	PRICE	SPREAD PORT #	13°, 15°, 16° CHEVY 18° #	PRICE	SB2 CHEVY #	PRICE
1 5/8"	3" x 8"	141-605LG	----	249.95	----	----	----	----	----
1 5/8" - 1 3/4"	3 1/2" x 8"	141-605LVG	141-605LVGCM	299.95	----	----	----	----	----
1 5/8" - 1 3/4"	3" x 8"	141-605LVG-3	141-605LVGCM-3	299.95	----	----	----	----	----
1 3/4"	3 1/2" x 8"	142-605LG	----	249.95	----	----	----	----	----
1 3/4" - 1 7/8"	3 1/2" x 9"	142-605LVG	142-605LVGCM	309.95	142-605LVGSP	142-605LVG18	369.95	142-605LVGSB2	419.95
1 7/8" - 2"	3 1/2" x 9"	143-605LVG	----	319.95	143-605LVGSP	143-605LVG18	379.95	143-605LVGSB2	429.95

Fits Mastersbilt, Warrior

505 OFF-SET

Available Brodix Spec. Head

TUBE DIAMETER	COLL. DIA. LENGTH	STANDARD CHEVY #	*CRATE MOTOR	PRICE	SPREAD PORT #	13°, 15°, 16° CHEVY 18° #	PRICE	SB2 CHEVY #	PRICE
1 5/8"	3" x 8"	141-505LG	----	249.95	----	----	----	----	----
1 5/8" - 1 3/4"	3 1/2" x 8"	141-505LVG	141-505LVGCM	299.95	----	----	----	----	----
1 5/8" - 1 3/4"	3" x 8"	141-505LVG-3	141-505LVGCM-3	299.95	----	----	----	----	----
1 3/4"	3 1/2" x 8"	142-505LG	----	249.95	----	----	----	----	----
1 3/4" - 1 7/8"	3 1/2" x 9"	142-505LVG	142-505LVGCM	309.95	142-505LVGSP	142-505LVG18	369.95	142-505LVGSB2	419.95
1 7/8" - 2"	3 1/2" x 9"	143-505LVG	----	319.95	143-505LVGSP	143-505LVG18	379.95	143-505LVGSB2	429.95



LEFT SIDE

Chevy Dirt Late Model



RIGHT SIDE

Fits Rocket, Bernheisel

525 OFF-SET

Available Brodix Spec. Head

TUBE DIAMETER	COLL. DIA. LENGTH	STANDARD CHEVY #	*CRATE MOTOR #	PRICE	SPREAD PORT #	13°, 15°, 16° CHEVY 18° #	PRICE	SB2 CHEVY #	PRICE
1 5/8"	3" x 8"	141-525L	----	249.95	----	----	----	----	----
1 5/8" - 1 3/4"	3 1/2" x 8"	141-525LV	----	299.95	----	----	----	----	----
1 5/8" - 1 3/4"	3" x 8"	141-525LV-3	141-525LVCM-3	299.95	----	----	----	----	----
1 3/4"	3 1/2" x 8"	142-525L	----	249.95	----	----	----	----	----
1 3/4" - 1 7/8"	3 1/2" x 9"	142-525LV	142-525LVCM	309.95	142-525LVSP	142-525LV18	369.95	142-525LVSB2	419.95
1 7/8" - 2"	3 1/2" x 9"	143-525LV	----	319.95	143-525LVSP	143-525LV18	379.95	143-525LVSB2	429.95

* = 604 Crate Motor Ceramic Coating add \$275.00

479-474-7529
 Fax # 479-474-2249
 Van Buren, AR
 www.SchoenfeldHeaders.com



Chevy LS1- LS7 Tri-Y Dirt Late Model

TUBE DIAMETER	COLLECTOR DIA./LENGTH	LS1 - LS7 CHEVY #	PRICE
1 3/4" - 1 7/8"	3 1/2" x 9"	14260LVYLS1	779.95

New!

New!



Fits Bob Pierce, GRT, Rayburn, Masterbilt, Larry Shaw, Rocket.

Fits most other chassis.

New! Chevy LS1- LS7 Dirt Late Model

Fits GRT, Stinger, TNT, Bob Pierce, Barry Wright, Bullitt, Larry Shaw, Raider, Warrior and Rayburn.

WILL NOT FIT GRT COMPUTER CAR

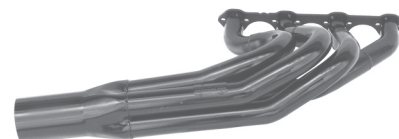

605 OFF-SET

TUBE DIAMETER	COLLECTOR DIA./LENGTH	LS1 - LS7 CHEVY #	PRICE
1 3/4"	3 1/2" x 8"	142-605LGLS1	319.95
1 3/4" - 1 7/8"	3 1/2" x 9"	142-605LVGLS1	379.95

G-RIGHT SIDE

Fits Rocket, Bernheisel

525 OFF-SET

TUBE DIAMETER	COLLECTOR DIA./LENGTH	LS1 - LS7 CHEVY #	PRICE
1 3/4"	3 1/2" x 8"	142-525L-LS1	319.95
1 3/4" - 1 7/8"	3 1/2" x 9"	142-525LVLS1	379.95



ROCKET RIGHT SIDE

Fits Mastersbilt, Warrior

505 OFF-SET

TUBE DIAMETER	COLLECTOR DIA./LENGTH	LS1 - LS7 CHEVY #	PRICE
1 3/4"	3 1/2" x 8"	142-505LGLS1	319.95
1 3/4" - 1 7/8"	3 1/2" x 9"	142-505LVGLS1	379.95

Tractor/Derby
 Dirt Mod.
 Crossover
 Drag 4 Cyl.
 Collector
 180° Crossover
 Collector
 Stock Clip
 Flanges/Gaskets
 Street Stock
 U & J Bends
 Chassis
 IMCA Mod.
 X & Y Pipes
 Turnouts & Extensions
 Sprint
 Misc.
 Midget
 Elbow Applications
 Chassis Applications
 Mufflers

Mopar Dirt Late Model

Mopar (Long primaries Both sides over frame)
Fits Bob Pierce, Barry Wright, Larry Shaw, GRT,
Stinger, TNT, Bullitt, Raider, and Rayburn

605 OFF-SET

TUBE DIAMETER	COLLECTOR DIA./LENGTH	STANDARD MOPAR #	*W-2 MOPAR #	W-9 MOPAR #	PRICE
1 5/8" - 1 3/4"	3 1/2" x 8"	441-605LVG	441-605LVGW2	----	369.95
1 5/8" - 1 3/4"	3" x 8"	441-605LVG-3	441-605LVGW2-3	----	369.95
1 3/4" - 1 7/8"	3 1/2" x 9"	442-605LVG	442-605LVGW2	442-605LVGW9	379.95
1 7/8" - 2"	3 1/2" x 9"	----	----	443-605LVGW9	389.95

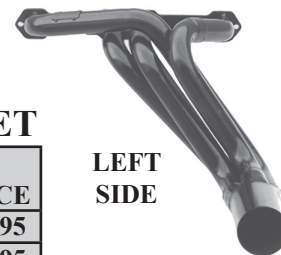

LEFT SIDE

G-RIGHT SIDE



Ceramic Coating add \$275.00

Mopar (Long primaries. Both sides over frame)
Fits Rocket, Bernheisel

525 OFF-SET

TUBE DIAMETER	COLLECTOR DIA./LENGTH	STANDARD MOPAR #	*W-2 MOPAR #	W-9 MOPAR #	PRICE
1 5/8" - 1 3/4"	3 1/2" x 8"	441-525LV	441-525LVW2	----	369.95
1 5/8" - 1 3/4"	3" x 8"	441-525LV-3	441-525LVW2-3	----	369.95
1 3/4" - 1 7/8"	3 1/2" x 9"	442-525LV	442-525LVW2	442-525LVW9	379.95
1 7/8" - 2"	3 1/2" x 9"	----	----	443-525LVW9	389.95



LEFT SIDE

RIGHT SIDE

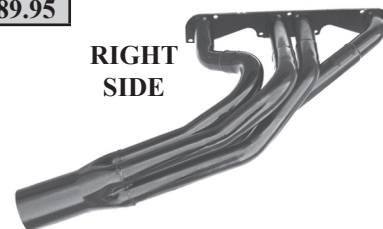

Ceramic Coating add \$275.00

Mopar (Long primaries Both sides over frame)
Fits Mastersbuilt

505 OFF-SET

TUBE DIAMETER	COLLECTOR DIA./LENGTH	STANDARD MOPAR #	*W-2 MOPAR #	W-9 MOPAR #	PRICE
1 5/8" - 1 3/4"	3 1/2" x 8"	441-505LVG	441-505LVGW2	----	369.95
1 5/8" - 1 3/4"	3" x 8"	441-505LVG-3	441-505LVGW2-3	----	369.95
1 3/4" - 1 7/8"	3 1/2" x 9"	442-505LVG	442-505LVGW2	442-505LVGW9	379.95
1 7/8" - 2"	3 1/2" x 9"	----	----	443-505LVGW9	389.95



LEFT SIDE

G-RIGHT SIDE

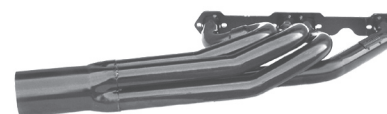

Ceramic Coating add \$275.00

W-2 & W-9 Headers do not include Gaskets.

479-474-7529
 Fax # 479-474-2249
 Van Buren, AR
 www.SchoenfeldHeaders.com



Ford Dirt Late Model

Redesigned for better fit, and performance.
 (Long primaries, both sides over frame rails)

For offset application refer to page 37

TUBE DIAMETER	COLLECTOR DIA./LENGTH	289-302-351 WINDSOR #	289-302-351 WINDSOR #	289-302-351 WINDSOR #	PRICE
1 5/8" - 1 3/4"	3 1/2" x 8"	341-605LVG	341-525LV	341-505LVG	359.95
1 5/8" - 1 3/4"	3" x 8"	341-605LVG-3	341-525LV-3	341-505LVG-3	359.95
1 3/4"	3 1/2" x 8"	342-605LG	342-525L	342-505LG	309.95
1 3/4" - 1 7/8"	3 1/2" x 9"	342-605LVG	342-525LV	342-505LVG	369.95



Left Side

(Also available for wide Dart bolt pattern and Sportsman "N" Head)

G-RIGHT SIDE

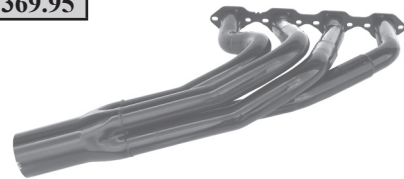

Ceramic Coating add \$275.00

Ford SVO C3/C33 Yates



TUBE DIAMETER	COLLECTOR DIA./LENGTH	ALUM. SVO SQ. PORT #	ALUM. SVO RND. PORT #	PRICE
1 3/4" - 1 7/8"	3 1/2" x 9"	642LV	642LVRP	379.95
1 7/8"	3 1/2" x 9"	643L	643LRP	379.95

Fits Rayburn, Rocket, GRT and most other chassis
 Does Not Include Gaskets

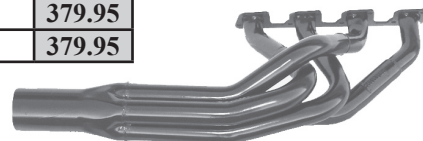

LS1 Comes With 5/16" Flange

TUBE DIAMETER	COLLECTOR DIA./LENGTH	LS1 #	PRICE
1 5/8" - 1 3/4"	3 1/2" x 13"	1022LV-LS1	359.95
1 3/4"	3 1/2" x 13"	1024L-LS1	309.95
1 3/4" - 1 7/8"	3 1/2" x 13"	1024LV-LS1	359.95

SB2

TUBE DIAMETER	COLLECTOR DIA./LENGTH	SB2 CHEVY #	PRICE
1 3/4" - 1 7/8"	3 1/2" x 13"	1014LVSB2	399.95
1 7/8"	3 1/2" x 13"	1015LSB2	349.95
1 7/8" - 2"	3 1/2" x 13"	1015LVSB2	399.95

Dyno/Sprint

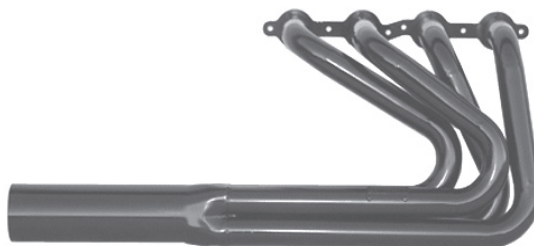

Bolts and Gaskets included

Big Block Chevy

TUBE DIAMETER	COLLECTOR DIA./LENGTH	BIG BLOCK #	PRICE
2"	3 1/2" x 13"	2016A	339.95
2"	4" x 13"	2016	339.95
2 1/8"	4" x 13"	2017	349.95
2 1/4"	4" x 13"	2018	359.95

Dyno/Sprint



Bolts and Gaskets included
 Comes With 5/16" Flange

Big Block Ford

TUBE DIAMETER	COLLECTOR DIA./LENGTH	429-460 FORD #	PRICE
2"	4" x 13"	6016	369.95
2 1/8"	4" x 13"	6017	379.95

Tractor/Derby
 Dirt Mod.
 Crossover
 Drag 4 Cyl.
 Collectors
 180° Crossover
 Flanges/Gaskets
 Stock Clip
 Street Stock
 U & J Pipes
 Chassis
 IMCA Mod.
 X & Y Pipes
 Turnouts & Extensions
 Misc.
 Midget Sprint
 Dirt Late Model
 Sprint
 Elbow Applications

Chevy Sprint Car Headers

Improved to fit raised rail. 32" Length primaries - 18 ga. Tubing.
 Removes over 200° of bend compared to normal header to increase flow.

Available with CNC laser cut flanges to fit:
 Brodix 18°, Standard Chevy 18°, Allen Johnson,
 Pontiac 867, Stahl.

TUBE DIAMETER	COLLECTOR DIA./LENGTH	STANDARD CHEVY #	SPREAD PORT/D.N #	ALL PRO GB 2300/2400 #	PRICE
1 5/8"	3" x 13"	1052L	----	----	209.95
1 5/8" - 1 3/4"	3 1/2" x 13"	1052LV	----	----	259.95
1 5/8" - 1 3/4"	3" x 13"	1052LV-3	----	----	259.95
1 3/4"	3 1/2" x 13"	1054L	----	----	209.95
1 3/4" - 1 7/8"	3 1/2" x 13"	1054LV	1054LVSP	----	269.95
1 7/8"	3 1/2" x 13"	1055L	1055LDN	1055LAP	219.95
1 7/8" - 2"	3 1/2" x 13"	1055LV	1055LVDN	1055LVAP	269.95
2"	3 1/2" x 13"	----	1056LDN	1056LAP	219.95

Welded to clear 4 inches from head to inside of header.



Straight tube Design

Ceramic coating add \$275.00

Bolts and Gaskets included
 Armor 400 Gaskets available for D.N & All Pro

Chevy Sprint Tri-Y Headers

4 Into 2 Into 1 Tube Configuration for Increased Torque

TUBE DIAMETER	COLLECTOR DIAMETER	STANDARD CHEVY #	SPREAD PORT/D.N #	PRICE
1 5/8" - 1 3/4"	3"	1062VY	----	639.95
1 3/4" - 1 7/8"	3 1/2"	1064VY	1064VYSP	629.95
1 7/8" - 2"	3 1/2"	1065VY	1065VYDN	649.95

Standard Design Bolts and Gaskets included

Comes With 5/16" Flange

Armor 400 Gaskets available for D.N & All Pro

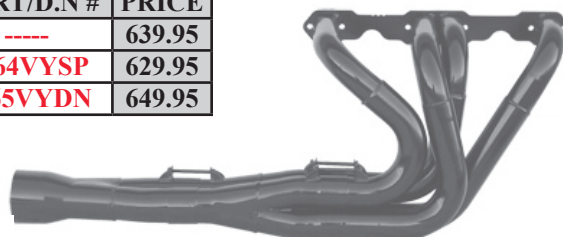

TUBE DIAMETER	COLLECTOR DIAMETER	STANDARD CHEVY #	SPREAD PORT/D.N #	PRICE
1 5/8" - 1 3/4"	3"	1022VY	----	649.95
1 3/4" - 1 7/8"	3 1/2"	1024VY	1024VYSP	649.95
1 7/8" - 2"	3 1/2"	1025VY	1025VYDN	669.95

Forward Design

Bolts and Gaskets included

Comes With 5/16" Flange

Armor 400 Gaskets available for D.N & All Pro

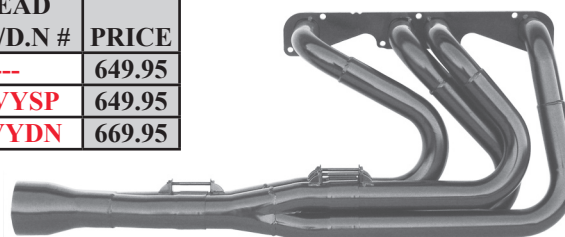



Chevy Sprint Car Headers

Improved to fit raised rail. 32" Primaries - 18 ga. Tubing.
Forward Design for additional muffler clearance



Cab Forward Design

TUBE DIAMETER	COLLECTOR DIA./LENGTH	STANDARD CHEVY #	SPREAD PORT/D.N #	ALL PRO GB23/24 #	PRICE
1 1/2" - 1 5/8"	3" x 13"	1021LV	----	----	269.95
1 5/8"	3" x 13"	1022L	----	----	219.95
1 5/8" - 1 3/4"	3 1/2" x 13"	1022LV	----	----	269.95
1 3/4"	3 1/2" x 13"	1024L	----	----	219.95
1 3/4" - 1 7/8"	3 1/2" x 13"	1024LV	1024LVSP	1024LVAP	269.95
1 7/8"	3 1/2" x 13"	1025L	1025LDN	1025LAP	219.95
1 7/8" - 2"	3 1/2" x 13"	1025LV	1025LVDN	1025LVAP	269.95
2"	3 1/2" x 13"	----	1026LDN	1026LAP	219.95

Armor 400 Gaskets available for D.N & All Pro

Bolts and Gaskets included

32" Primaries - 18 ga. Tubing CNC Laser Cut flange

TUBE DIAMETER	COLLECTOR DIA./LENGTH	SPREAD PORT #	PRICE
1 3/4" - 1 7/8"	3 1/2" x 13"	1014LVSP	269.95
1 7/8"	3 1/2" x 13"	1015LDN	219.95
1 7/8" - 2"	3 1/2" x 13"	1015LVDN	269.95
2"	3 1/2" x 13"	1016LDN	219.95



Standard Design

Welded to clear 4 inches from head to inside of header.
 Bolts and Gaskets included
 Armor 400 Gaskets available for D.N & All Pro

Available for All Pro & Brodix GB heads

32" Primaries

Ceramic coating add \$275.00



Standard Design

TUBE DIAMETER	COLLECTOR DIA./LENGTH	STANDARD CHEVY #	PRICE
1 1/2" - 1 5/8"	3" x 8"	1011LV	269.95
1 5/8"	3" x 8"	1012L	199.95
1 5/8" - 1 3/4"	3 1/2" x 8"	1012LV	259.95
1 5/8" - 1 3/4"	3" x 8"	1012LV-3	259.95
1 3/4"	3 1/2" x 8"	1014L	189.95
1 3/4" - 1 7/8"	3 1/2" x 9"	1014LV	259.95
1 7/8"	3 1/2" x 9"	1015L	219.95
1 7/8" - 2"	3 1/2" x 9"	1015LV	269.95

Bolts and Gaskets included

Chevy Asphalt Sprint

TUBE DIAMETER	COLLECTOR DIA./LENGTH	SPREAD PORT/D.N #	PRICE
1 3/4" - 1 7/8"	3 1/2" x 13"	1034LVSP	369.95
1 7/8" - 2"	3 1/2" x 13"	1035LVDN	369.95

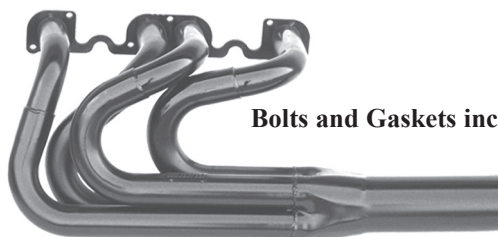

Bolts and Gaskets included

Available for All Pro & Brodix GB heads

Armor 400 Gaskets available for D.N & All Pro

Tractor/Derby
 Crossover
 Drag 4 Cyl.
 Crossover
 Collectors
 180° Crossover
 Gaskets
 Stock Clip
 Flanges/Gaskets
 Street Stock
 U & J Bends
 Chassis
 X & Y Pipes
 IMCA Mod.
 Turnouts & Extensions
 Sprint
 Misc.
 Midget
 Elbow Applications
 Chassis Applications
 Mufflers

Sprint Car "Lite Series" Headers

Light weight, laser cut flanges (weigh under 1 lb.)

Available with CNC laser cut flanges to fit:
 Brodix 18°, Standard Chevy 18°, Allen Johnson, Mopar and Pontiac 867, Stahl.
 Ceramic coating add \$275.00.

Improved to fit raised rail. 32" Length primaries - 20 ga tubing
 Removes over 200° of bend compared to normal header to increase flow.

TUBE DIAMETER	COLLECTOR DIA./LENGTH	STANDARD CHEVY #	SPREAD PORT/D.N #	PRICE
1 7/8" - 2"	3 1/2" x 13"	1055LVT	1055LVDNT	299.95
2"	3 1/2" x 13"	----	1056LDNT	269.95

Available for All Pro & Brodix GB heads

Welded to clear 4 inches from head to inside of header.



Straight Tube Design

Weight Example: 1 7/8" Diameter header weighs approx. 21 lbs. as pictured. Flange and collector may be trimmed for further weight reduction.

Standard Design

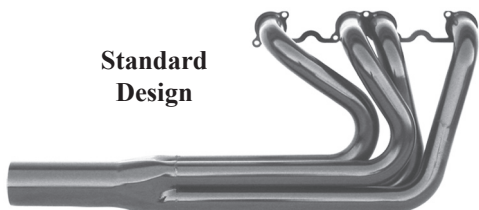

32" Primaries - 20 ga. tubing

TUBE DIAMETER	COLLECTOR DIA./LENGTH	STANDARD CHEVY #	SPREAD PORT/D.N #	PRICE
1 7/8" - 2"	3 1/2" x 13"	1015LVT	1015LVDNT	299.95
2"	3 1/2" x 13"	----	1016LDNT	269.95

32" Primaries - 20 ga. tubing

Forward Design for additional muffler clearance

TUBE DIAMETER	COLLECTOR DIA./LENGTH	STANDARD CHEVY #	SPREAD PORT/D.N #	PRICE
1 7/8"	3 1/2" x 13"	1025LT	-----	249.95
1 7/8" - 2"	3 1/2" x 13"	1025LVT	1025LVDNT	299.95
2"	3 1/2" x 13"	----	1026LDNT	269.95

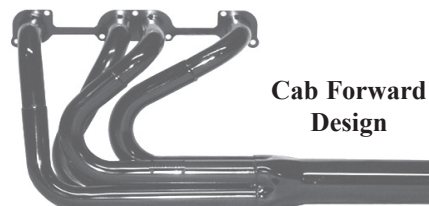

Cab Forward Design

Available for All Pro & Brodix GB heads
 Armor 400 Gaskets available for D.N & All Pro

479-474-7529
 Fax # 479-474-2249
 Van Buren, AR
 www.SchoenfeldHeaders.com



Mopar Sprint Tri-Y Headers

4 Into 2 Into 1 Tube Configuration for Increased Torque

TUBE DIAMETER	COLLECTOR DIA./LENGTH	W9 #	W9 RAISED PORT #	PRICE
1 3/4" - 1 7/8"	3 1/2"	4064VYW9	4064VYW9RP	729.95
1 7/8" - 2"	3 1/2"	4065VYW9	4065VYW9RP	729.95

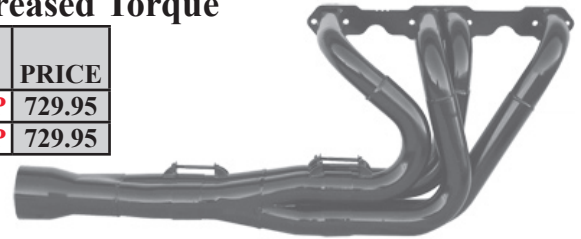

Does not include Gaskets.

Mopar Sprint Car Headers

Straight tube design removes over 200° of bend compared to normal header to increase exhaust flow.

W-2 & W-9 Headers do not include Gaskets.

Straight tube Design

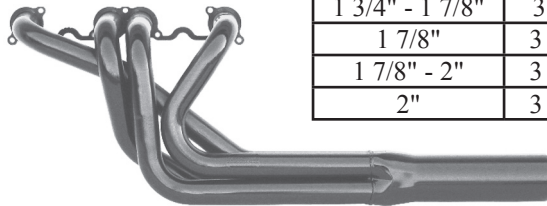

TUBE DIAMETER	COLLECTOR DIA./LENGTH	STANDARD MOPAR #	W-2 MOPAR #	W-9 MOPAR #	PRICE
1 5/8"	3" x 13"	4052L	4052LW2	----	279.95
1 5/8" - 1 3/4"	3 1/2" x 13"	4052LV	4052LVW2	----	329.95
1 5/8" - 1 3/4"	3" x 13"	4052LV-3	4052LVW2-3	----	329.95
1 3/4"	3 1/2" x 13"	4054L	4054LW2	----	279.95
1 3/4" - 1 7/8"	3 1/2" x 13"	4054LV	4054LVW2	----	339.95
1 7/8"	3 1/2" x 13"	----	----	4055LW9	299.95
1 7/8" - 2"	3 1/2" x 13"	----	----	4055LVW9	349.95
2"	3 1/2" x 13"	----	----	4056LW9	299.95

Ceramic coating add \$275.00
 (Available: W-5 or W-7)

Forward Design for additional muffler clearance

Cab Forward Design



Cab Forward Design

TUBE DIAMETER	COLLECTOR DIA./LENGTH	STANDARD MOPAR #	W-2 MOPAR #	W-9 MOPAR #	PRICE
1 5/8"	3" x 13"	4022L	4022LW2	----	279.95
1 5/8" - 1 3/4"	3 1/2" x 13"	4022LV	4022LVW2	----	329.95
1 3/4"	3 1/2" x 13"	4024L	4024LW2	----	279.95
1 3/4" - 1 7/8"	3 1/2" x 13"	4024LV	4024LVW2	4024LVW9	339.95
1 7/8"	3 1/2" x 13"	----	----	4025LW9	299.95
1 7/8" - 2"	3 1/2" x 13"	----	----	4025LVW9	349.95
2"	3 1/2" x 13"	----	----	4026LW9	299.95

(Available: W-5 or W-7)

Ford Sprint Car Header

(Available for Edelbrock)

Forward Design for additional muffler clearance

TUBE DIAMETER	COLLECTOR DIA./LENGTH	289-302-351 WINDSOR #	DART/"N" SPORTSMAN #	PRICE
1 5/8"	3" x 13"	3022L	*3022LN	269.95
1 5/8" - 1 3/4"	3 1/2" x 13"	3022LV	*3022LVN	319.95
1 3/4"	3 1/2" x 13"	3024L	*3024LN	269.95
1 3/4" - 1 7/8"	3 1/2" x 13"	3024LV	*3024LVN	329.95

*Fits the wide Dart bolt pattern and Sportsman "N" head

Cab Forward Design



Chassis Applications Midget Sprint Dirt Late Model IMCA Mod. Chassis Street Stock Stock Clip 180° Crossover Crossover Tractor/Derby Mufflers Elbow Applications Misc. Turnouts & Extensions X & Y Pipes U & J Bends Flanges/Gaskets Collectors Drag 4 Cyl. Dirt Mod.

Chevy Midget Tri-Y

4 Into 2 Into 1 Tube Configuration for Increased Torque

TUBE DIAMETER	COLLECTOR DIAMETER	SPREAD PORT #	PRICE
1 3/4" - 1 7/8"	3"	1074VYSPM-6	399.95
1 7/8" - 2"	3"	1075VYDNM-6	399.95

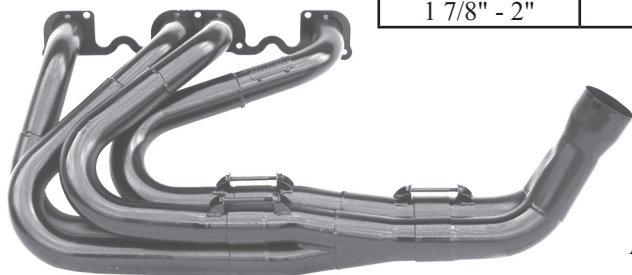

Available for All Pro & Brodix GB heads
 Comes With 5/16" Flange
 Bolts and Gaskets included
 Armor 400 Gaskets available for D.N & All Pro

New! Chevy Midget Merge

TUBE DIAMETER	COLLECTOR DIAMETER	SPREAD PORT #	PRICE
1 3/4" - 1 7/8"	3"	1084VSPMM	399.95
1 7/8" - 2"	3"	1085VDNMM	399.95

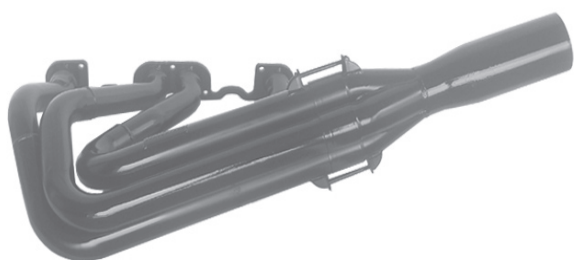

Available for All Pro & Brodix GB heads
 Comes With 5/16" Flange
 Bolts and Gaskets included
 Armor 400 Gaskets available for D.N & All Pro
 Available with Tri-Y collectors

Chevy Midget Header

TUBE DIAMETER	COLLECTOR DIA./LENGTH	SPREAD PORT/D.N. #	PRICE
1 3/4" - 1 7/8"	3 1/2" x 13"	1044LVSPM	239.95
1 7/8" - 2"	3 1/2" x 13"	1045LVDNM	239.95

Available for All Pro & Brodix GB heads



Mopar Midget Tri-Y Headers

4 Into 2 Into 1 Tube Configuration for Increased Torque

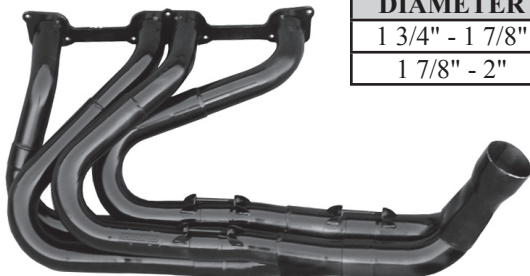

TUBE DIAMETER	COLLECTOR DIA.	W-9 MOPAR #	W-9 RAISED PORT #	PRICE
1 3/4" - 1 7/8"	3"	4074VYW9M-6	4074VYW9RPM-6	419.95
1 7/8" - 2"	3"	4075VYW9M-6	4075VYW9RPM-6	419.95

Does not include Gasket.

New!

Toyota Midget Header

New!



UPSWEPT

MERGE COLL.

Comes With 5/16" Flange

TUBE DIAMETER	COLLECTOR DIA./STYLE	TOYOTA #	PRICE
1 3/4" - 1 7/8"	3" MERGE	T1034VAMM	429.95
1 3/4" - 1 7/8" - 2"	3" MERGE	T1034V3AMM	479.95
1 7/8" - 2"	3" MERGE	T1035VAMM	429.95

Fontana Midget Header

Comes With 5/16" Flange

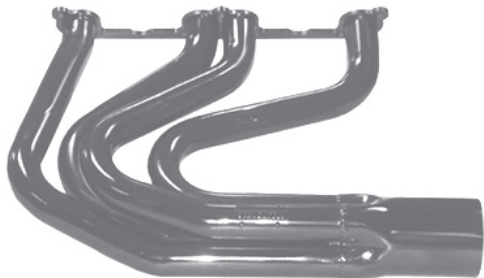

Does not include Gasket.

TUBE DIAMETER	COLLECTOR DIA.	FONTANA #	PRICE
1 7/8"	4"	9045-4	249.95
1 7/8" - 2"	4"	9045V	269.95
2"	4"	9045-4	249.95
1 7/8" - 2" - 2 1/8"	3 1/2"	9045V3M	499.95

9045V3M - With Merge Coll.

Available in Upswept design

Esslinger Midget Header

Designed to fit ESSLINGER ST/XT engines.

Headers come with 5/16" flange

TUBE DIAMETER	COLLECTOR DIA./STYLE	ESSLINGER #	PRICE
1 3/4" - 1 7/8" - 2"	3" MERGE	9174V3MM	449.95
1 3/4" - 1 7/8" - 2"	3" TRI-Y	9174V3YM	449.95

Does not include Gasket.



MERGE COLL.



TRI-Y

New! Esslinger Midget Header

Designed to fit ESSLINGER RSI engines.

Headers come with 5/16" flange

TUBE DIAMETER	COLLECTOR DIA./STYLE	UPSWEPT ESSLINGER #	PRICE	TUBE DIAMETER	COLLECTOR DIA./STYLE	ESSLINGER #	PRICE
1 3/4" - 1 7/8" - 2"	3" MERGE	9174V3MMRU	449.95	1 3/4" - 1 7/8" - 2"	3" MERGE	9174V3MMR	449.95

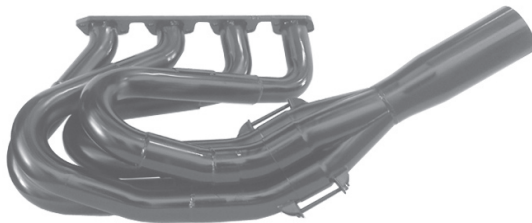

UPSWEPT MERGE

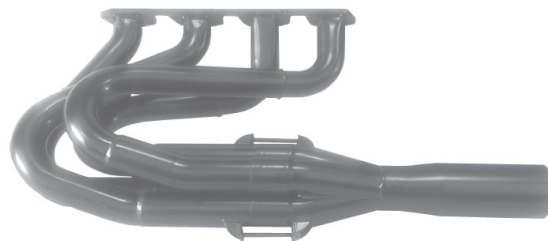

MERGE



New! Mini/Micro Sprint Tri-Y Header

TUBE DIAMETER	COLLECTOR DIAMETER	YAMAHA R6 4-2-1 COLL. #	PRICE
1 3/8"	1 3/4"	MS600RY-6	289.95
1 3/8" - 1 1/2"	1 3/4"	MS603RVY-6	289.95

TUBE DIAMETER	COLLECTOR DIAMETER	YAMAHA R6R 4-2-1 COLL. #	PRICE
1 3/8" - 1 1/2"	1 3/4"	MS603RVYR-6	289.95

TUBE DIAMETER	COLLECTOR DIAMETER	KAW. 636 4-2-1 COLL. #	PRICE
1 3/8" - 1 1/2"	1 3/4"	MS503RVY-6	289.95

TUBE DIAMETER	COLLECTOR DIAMETER	KAW. 600 4-2-1 COLL. #	PRICE
1 3/8" - 1 1/2"	1 3/4"	MS503RVYR-6	289.95

TUBE DIAMETER	COLLECTOR DIAMETER	HONDA 600RR 4-2-1 COLL. #	PRICE
1 3/8" - 1 1/2"	1 3/4"	MS403RVYR-6	289.95

TUBE DIAMETER	COLLECTOR DIAMETER	HONDA 600F4I 4-2-1 COLL. #	PRICE
1 3/8" - 1 1/2"	1 3/4"	MS403FVY-6	289.95

TUBE DIAMETER	COLLECTOR DIAMETER	SUZUKI GSXR 4-2-1 COLL. #	PRICE
1 3/8" - 1 1/2"	1 3/4"	MS703RVYR-6	289.95



left side exit



elbow



muffler

Ceramic coating add \$175.00

Available with 2" collector

Part # MS131722 - 1 3/4" INLET \$49.95

Part # MS132022 - 2" INLET \$49.95

New! Over The Top Mini/Micro Tri-Y

TUBE DIAMETER	COLLECTOR DIAMETER	YAMAHA R6 4-2-1 COLL. #	PRICE
1 3/8" - 1 1/2"	1 3/4"	MS613RVY-4	289.95

TUBE DIAMETER	COLLECTOR DIAMETER	YAMAHA R6R 4-2-1 COLL. #	PRICE
1 3/8" - 1 1/2"	1 3/4"	MS613RVYR-4	289.95

TUBE DIAMETER	COLLECTOR DIAMETER	KAW. 636 4-2-1 COLL. #	PRICE
1 3/8" - 1 1/2"	1 3/4"	MS513RVY-4	289.95

TUBE DIAMETER	COLLECTOR DIAMETER	KAW. 600 4-2-1 COLL. #	PRICE
1 3/8" - 1 1/2"	1 3/4"	MS513RVYR-4	289.95

TUBE DIAMETER	COLLECTOR DIAMETER	HONDA 600RR 4-2-1 COLL. #	PRICE
1 3/8" - 1 1/2"	1 3/4"	MS413RVYR-4	289.95

TUBE DIAMETER	COLLECTOR DIAMETER	HONDA 600F4I 4-2-1 COLL. #	PRICE
1 3/8" - 1 1/2"	1 3/4"	MS413FVY-4	289.95

TUBE DIAMETER	COLLECTOR DIAMETER	SUZUKI GSXR 4-2-1 COLL. #	PRICE
1 3/8" - 1 1/2"	1 3/4"	MS713RVYR-4	289.95



left side exit



elbow



muffler

Available with 2" collector

Ceramic coating add \$175.00

Part # MS131722 - 1 3/4" INLET \$49.95

Part # MS132022 - 2" INLET \$49.95

Chassis Applications | Mini Sprint | Dirt Late Model | IMCA Mod. | Chassis | Street Stock | Stock Clip | 180° Crossover | Crossover | Tractor/Derby | Mufflers | Elbow Applications | Misc. | Turnouts & Extensions | X & Y Pipes | U & J Bends | Flanges/Gaskets | Collectors | Drag | 4 Cyl. | Dirt Mod.



479-474-7529
 Fax # 479-474-2249
 Van Buren, AR
www.SchoenfeldHeaders.com

New! Mini/Micro Sprint Tri-Y Header

WITH 1 1/4" INSERT

TUBE DIAMETER	COLLECTOR DIAMETER	YAMAHA R6 4-2-1 COLL. #	PRICE
1 3/8"	1 3/4"	MS602RY-4	289.95
1 3/8" - 1 1/2"	1 3/4"	MS602RVY-4	289.95

TUBE DIAMETER	COLLECTOR DIAMETER	YAMAHA R6 4-2-1 COLL. #	PRICE
1 3/8"	1 3/4"	MS602RIY-4	289.95
1 3/8" - 1 1/2"	1 3/4"	MS602RIVY-4	289.95

TUBE DIAMETER	COLLECTOR DIAMETER	KAW. 636 4-2-1 COLL. #	PRICE
1 3/8"	1 3/4"	MS502RY-4	289.95
1 3/8" - 1 1/2"	1 3/4"	MS502RVY-4	289.95

TUBE DIAMETER	COLLECTOR DIAMETER	KAW. 636 4-2-1 COLL. #	PRICE
1 3/8"	1 3/4"	MS502RIY-4	289.95
1 3/8" - 1 1/2"	1 3/4"	MS502RIVY-4	289.95

TUBE DIAMETER	COLLECTOR DIAMETER	HONDA 600RR 4-2-1 COLL. #	PRICE
1 3/8"	1 3/4"	MS402RYR-4	289.95
1 3/8" - 1 1/2"	1 3/4"	MS402RVYR-4	289.95

TUBE DIAMETER	COLLECTOR DIAMETER	HONDA 600RR 4-2-1 COLL. #	PRICE
1 3/8"	1 3/4"	MS402RIYR-4	289.95
1 3/8" - 1 1/2"	1 3/4"	MS402RIVYR-4	289.95

TUBE DIAMETER	COLLECTOR DIAMETER	SUZUKI GSXR 4-2-1 COLL. #	PRICE
1 3/8"	1 3/4"	MS702RYR-4	289.95
1 3/8" - 1 1/2"	1 3/4"	MS702RVYR-4	289.95

TUBE DIAMETER	COLLECTOR DIAMETER	SUZUKI GSXR 4-2-1 COLL. #	PRICE
1 3/8"	1 3/4"	MS702RIYR-4	289.95
1 3/8" - 1 1/2"	1 3/4"	MS702RIVYR-4	289.95

New!

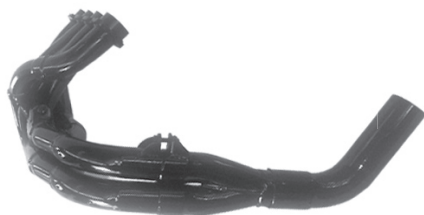

LEFT SIDE EXIT

New!

Available with 2" collector



Mod-Lite Tri-Y Headers

TUBE DIAMETER	COLLECTOR DIAMETER	SUZUKI GSXR 1000 4-2-1 COLL. #	PRICE
1 1/2"	2"	ML11703RY	289.95
1 1/2" - 1 5/8"	2"	ML11703RVY	339.95

New!

1978-1987 Chevy Truck Headers

New!

16 ga. primaries, excellent spark plug access.
 Fits straight or angle plugs.

TUBE DIAMETER	COLLECTOR DIA./LENGTH	STANDARD CHEVY #	PRICE
1 5/8"	3" x 8"	1307	279.95
1 3/4"	3" x 8"	1308-3	279.95
1 7/8"	3" x 9"	1309-3	379.95
1 7/8"	3 1/2" x 9"	1309	379.95

Bolts and Gaskets included

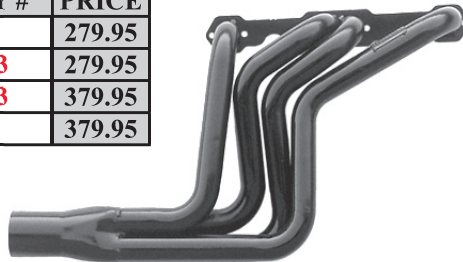
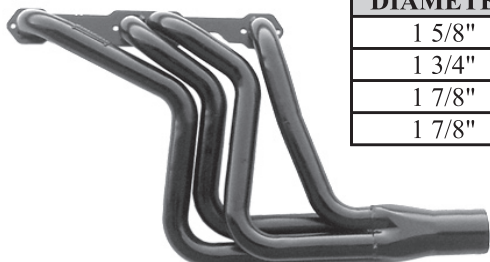

www.SchoenfeldHeaders.com

Tractor/Truck
 Dirt Mod.
 4 Cyl. Drag
 Crossover
 Collectors
 180° Crossover
 Flanges/Gaskets
 Stock Clip
 Street Stock
 U & J Bends
 Chassis
 X & Y Pipes
 IMCA Mod.
 Turnouts & Extensions
 Dirt Late Model
 Sprint
 Misc.
 Midget
 Chassis Applications
 Elbow Applications
 Mufflers

479-474-7529
 Fax # 479-474-2249
 Van Buren, AR
 www.SchoenfeldHeaders.com



Chevy D.I.R.T. Modified Headers

Ceramic Coating
 add \$275.00

Fits Bicknell, Olsen, TEO, Troyer

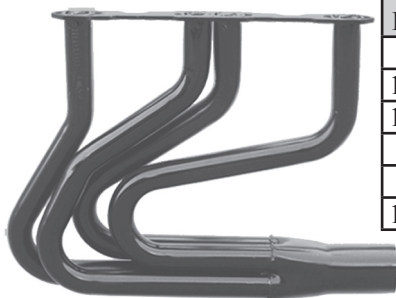

TUBE DIAMETER	COLL. DIA./LNGTH	STANDARD CHEVY #	*CRATE MOTOR #	SPEC. HEAD #	PRICE
1 5/8"	3" x 8"	1122B	1122BCM	----	249.95
1 5/8" - 1 3/4"	3" x 8"	1122BV-3	1122BVCM-3	1122BVSH-3	299.95
1 5/8" - 1 3/4"	3 1/2" x 8"	1122BV	1122BVCM	----	299.95
1 3/4"	3" x 8"	1124B-3	----	----	249.95
1 3/4"	3 1/2" x 8"	1124B	----	----	249.95
1 3/4" - 1 7/8"	3 1/2" x 9"	1124BV	----	----	309.95

Cab Forward Design for Additional Muffler Clearance
 Slip on collector available. Add \$50.00

Mopar available * = 602 Crate Motor

D.I.R.T. Modified Tri-Y Headers



4 Into 2 Into 1 Tube Configuration
 for Increased Torque

TUBE DIAMETER	COLLECTOR DIA.	STANDARD CHEVY #	PRICE
1 5/8" - 1 3/4"	3"	1122VY	689.95
1 3/4" - 1 7/8"	3 1/2"	1124VY	689.95

Comes With 5/16" Flange

D.I.R.T. Modified Tri-Y Headers

Fits Bicknell, Olsen, TEO, Troyer
 Cab Forward Design for Additional Muffler Clearance

TUBE DIAMETER	COLLECTOR DIA./LENGTH	BIG BLOCK #	PRICE
2"	3 1/2" x 9"	2123	269.95

Big Block
 Chevy



Comes With 5/16" Flange

Ford D.I.R.T. Modified Header

Fits Bicknell, Olsen, TEO, Troyer
 Cab Forward design for additional muffler clearance

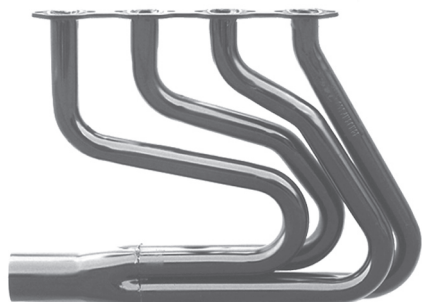

(Available for Edelbrock)

TUBE DIAMETER	COLLECTOR DIA./LENGTH	289-302-351 WINDSOR #	DART/"N" #	PRICE
1 5/8"	3" x 8"	3122B	*3122BN	299.95
1 5/8" - 1 3/4"	3 1/2" x 8"	3122BV	*3122BVN	349.95
1 5/8" - 1 3/4"	3" x 8"	3122BV-3	*3122BVN-3	349.95
1 3/4"	3 1/2" x 8"	3124B	*3124BN	299.95
1 3/4"	3" x 8"	3124B-3	*3124BN-3	299.95
1 3/4" - 1 7/8"	3 1/2" x 9"	3124BV	*3124BVN	359.95

*Fits wide Dart bolt pattern and Sportsman "N" head.
 Slip on collector available. Add \$50.00

Tractor/Derby
 Crossover
 Drag 4 Cyl.
 Collector
 180° Crossover
 Stock Clip
 Flanges/Gaskets
 Street Stock
 U & J Bends
 Chassis
 X & Y Pipes
 IMCA Mod.
 Turnouts & Extensions
 Dirt Late Model
 Sprint
 Misc.
 Midget
 Elbow Applications
 Chassis Applications
 Mufflers

2300cc Ford Pinto Tri - Y Headers

TUBE DIAMETER	COLLECTOR DIAMETER	2300CC #	PRICE
1 1/2" - 1 5/8"	3"	F232VY	349.95
1 5/8" - 1 3/4"	3"	F233VY	349.95

Bolts and Gaskets included

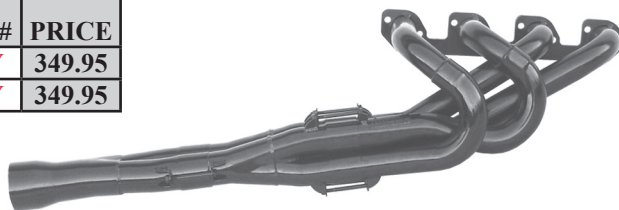

2000cc & 2300cc Ford Pinto Headers

“Pro Four” Tube Chassis Style or goes through Firewall on production Pinto or Mustang.

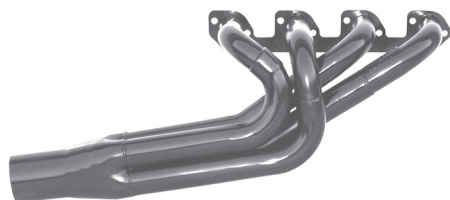

TUBE DIAMETER	COLLECTOR DIA./LENGTH	2300CC #	2000CC #	PRICE
1 1/2" - 1 5/8"	3" x 8"	F234V	F204V	149.95
1 5/8" - 1 3/4"	3" x 8"	F235V	F205V	149.95
GASKETS	----	FG23	FG20	10.50

Bolts and Gaskets included

Production Chassis type:
 (exits under car on production Pinto or Mustang)
 Will not clear 2.0 stock motor mounts.

TUBE DIAMETER	COLLECTOR DIA./LENGTH	2300CC #	2000CC #	PRICE
1 1/2" - 1 5/8"	3" x 8"	F238V	F208V	159.95
1 5/8" - 1 3/4"	3" x 8"	F239V	F209V	159.95
GASKETS	----	FG23	FG20	10.50

Also fits Ford Ranger 1983-1992



Bolts and Gaskets included

New! LS1-LS7 Truck

1973-Early 1999 Truck

5/16" flange, 16 ga. primaries, O2 sensor bungs installed in collector, excellent spark plug access.

TUBE DIAMETER	COLLECTOR DIA./LENGTH	LS1 #	PRICE
1 3/4"	3" x 8"	1302LS1	299.95
1 3/4" - 1 7/8"	3" x 9"	1302VLS1-3	379.95
1 7/8"	3" x 9"	1303LS1-3	399.95

Bolts and Gaskets included

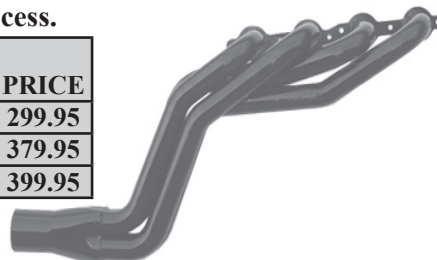
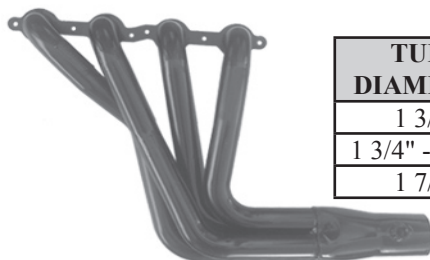

These products are intended for racing and off-road applications. Not legal for sale or use in the state of California, nor in states which have adopted California emission standards.

479-474-7529
 Fax # 479-474-2249
 Van Buren, AR
 www.SchoenfeldHeaders.com



Truck / Tractor Pull

Small Block Chevy – 28" Primaries - 5/16 Flange

TUBE DIAMETER	COLLECTOR DIA./LENGTH	STANDARD CHEVY #	PRICE	CAB FORWARD #	PRICE
1 5/8"	3" x 8"	1512	209.95	1532	219.95
1 3/4"	3 1/2" x 8"	1514	239.95	1534	249.95
1 3/4"	3 1/2" x 8"	1514-LS1	289.95	-----	-----
1 7/8"	3 1/2" x 9"	1515	279.95	1535	289.95

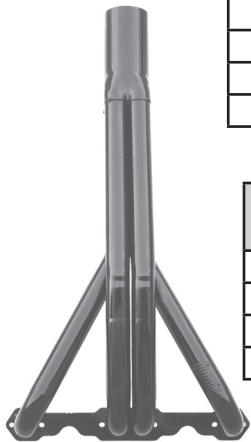

Big Block Chevy – 31" Primaries - 5/16" Flange

TUBE DIAMETER	COLLECTOR DIA./LENGTH	STANDARD CHEVY #	PRICE	CAB FORWARD #	PRICE
1 5/8"	3" x 8"	2512	289.95	2532	299.95
2"	4" x 10"	2516	369.95	2536	379.95
2 1/8"	4" x 10"	2517	369.95	2537	379.95
2 1/4"	4" x 10"	2518	379.95	2538	389.95

With evacuation tubes add \$40.00

All Tractor Pull Available with Merge Coll. add \$380.00

429-460 Big Block Ford - 30" Primaries

May not fit with power brake booster. - 5/16" Flange

TUBE DIAMETER	COLLECTOR DIA./LENGTH	429-460 FORD #	PRICE
2"	4" x 10"	6516	379.95
2 1/8"	4" x 10"	6517	399.95

Cab forward available

Small Block Ford Windsor - 29" Primaries

TUBE DIAMETER	COLLECTOR DIA./LENGTH	289-302-351 WINDSOR #	*DART/"N" SPORTSMAN #	PRICE
1 5/8"	3" x 8"	3512	3512N	249.95
1 3/4"	3 1/2" x 8"	3514	3514N	259.95

Cab forward available

Big Block Mopar - 28" Primaries

Does Not Include Gaskets

TUBE DIAMETER	COLLECTOR DIA./LENGTH	MOPAR 440 #	PRICE
1 7/8"	3 1/2" x 9"	7515	379.95
2"	4" x 10"	7516	389.95

Demolition Derby

Chevy / Ford / Mopar (Exits thru hood)

TUBE DIAMETER	STANDARD CHEVY #	WINDSOR 289-302-351 #	MOPAR 318-340-360 #	MOPAR 361-383-440 #	PRICE
1 5/8"	1522	3522	4522	-----	129.95
1 3/4"	-----	-----	-----	7524	149.95

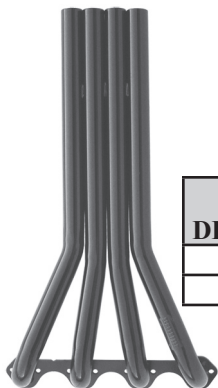

Chassis Applications | Midget | Sprint | Dirt Late Model | IMCA Mod. | Chassis | Street Stock | Stock Clip | 180° Crossover | Crossover | Tractor/Derby
 Mufflers | Elbow Applications | Misc. | Turnouts & Extensions | X & Y Pipes | U & J Bends | Flanges/Gaskets | Collectors | Drag | 4 Cyl. | Dirt Mod.



479-474-7529
 Fax # 479-474-2249
 Van Buren, AR
 www.SchoenfeldHeaders.com

IMCA Modified

CHASSIS	162-68	162-98H	11629H	152-152E	162	172-176	1101	1146	1155L	1176	1186	1166	1106
AMERICAN	X			X	X								
BMS	X	X			X	X		X		X	X		X
BOB PIERCE				X	X	X					X		X
D&M				X	X	X				0	0		
DIRTWORKS		X		X	X	X				X	X		X
DW-8		X		X	X	X				X	X		
FLEXIFLYER	X			X	X								
FR 1				X		X					X		
EDGE	X	X		X	X	X				X	X		X
GRT	X			X	X					3	2		X
HARRIS	X	X	X	X	X	X	X			X	0		X
HOFFMAN				X	X	X	X	0		X	X	0	X
HOT CHASSIS				X	X	X				X	X		
HUGHES	X	X	X		X	X		X		X	X	X	X
J CAR												X	
JET RACING	X	X		X	X	X				X	X		X
KRAFT		X										X	
LARRY SHAW	X			X	X	X		X	X	X	X	0	X
LG2													
LIGHTNING					X	X				X			
LOU FEGERS					X					X	1		
M & M										X	0		
PRO-CHASSIS	X			X	X	0				X	X		
QUICK					X						X		
RAGE												X	
RAZOR								X			X		
SARDESON	X	X		X	X	X				X	X		
SKYROCKET		X	X		X	X							X
SMILEYS	X	X		X	X	X					X		
SPEEDWAY		X		X	X	X							
SWARTZ				X		X							
SYCLONE	X			X	X	X					X		X
TRE								X			X	X	

X = FITS SPECIFIED CHASSIS
 O = DOESN'T FIT CHASSIS
 1 = FITS FEGERS 2002
 2 = FITS GRT (CHEVELLE FRONT CLIP)
 3 = FITS METRIC FRONT CLIP (#340 & Up)

D.I.R.T. Mod.

CHASSIS	1124B	2123
BICKNELL	X	X
OLSEN	X	X
TEO	X	X
TROYER	X	X

Asphalt Late Model

CHASSIS	136	136H	H180	D180
BEMCO	X		X	
COLEMAN	X		X	
DILLON				X
HAMKE	X			
HOWE		X	X	
LEFTHANDER	X		X	
PORT CITY		X	X	

Dirt Late Model

CHASSIS	142-505LG 142-505LGSP	142-525L 142-525SLSP	142-605LG 142-605LGSP
AMERICAN MADE			X
BARRY WRIGHT			X
BERNHEISEL		X	
BOB PIERCE			X
BULLITT			X
GRT			X
LARRY SHAW			X
LOU FEGERS			X
MASTERSBILT	X		
RAIDER			X
RAYBURN			X
ROCKET		X	
STINGER			X
TNT			X
WARRIOR	X 2005-2006 1997 OLDER		X 1998-2004 2007-2009

Special Pricing

SPECIAL ITEMS	ADD
Special Offset	\$ 150.00
Coating	\$ 275.00
Merge Collectors	\$380.00
W/O» S/O Coll.	\$ 50.00
E-Vacs welded in	\$40.00
O2 Bungs welded in	\$40.00
Additional Welding (muffler, elbow)	\$ 40.00

Tractor/Derby
 4 Cyl. Drag
 Collectors
 180° Crossover
 Flanges/Gaskets
 Stock Clip
 Street Stock
 U & J Bends
 Chassis
 X & Y Pipes
 IMCA Mod.
 Turnouts & Extensions
 Dirt Late Model
 Sprint
 Misc.
 Elbow Applications
 Mufflers
 Midget
 Chassis Applications

479-474-7529
 Fax # 479-474-2249
 Van Buren, AR
www.SchoenfeldHeaders.com



Flanges price per each
 * = 5/16" thick

Flanges & Gaskets Small Block Chevy

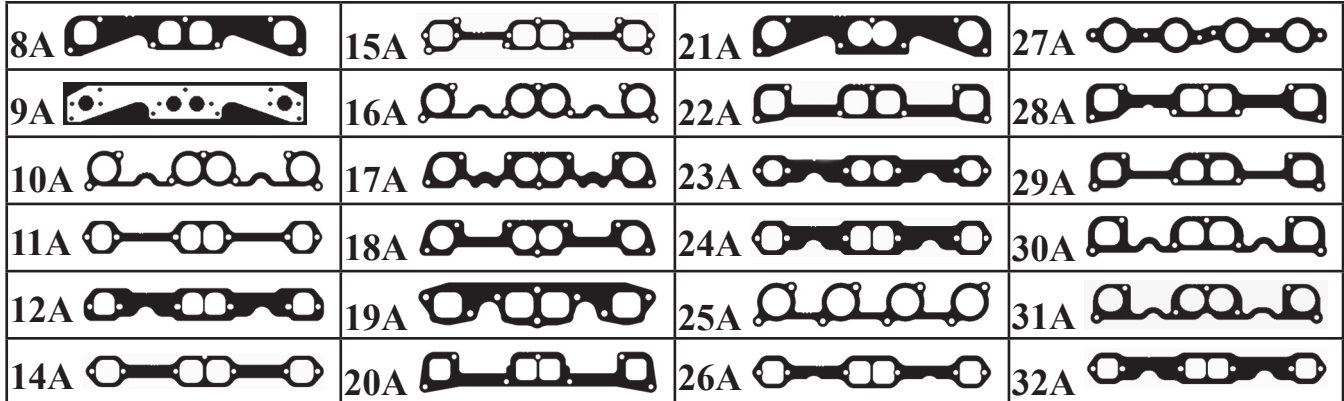

REF#	CYLINDER HEAD DESCRIPTION	TUBE DIA.	PORT SHAPE	STAMP/ CNC	FLANGE PART #	FLANGE PRICE	GASKET PART #	GASKET PRICE
9A	23° SB ADAPTER KIT (2 PLATES, 2 INNER GASKETS & BOLTS)	1 1/4"	ROUND	CNC	0101K	114.95	01511	INCL.
9A	23° SB ADAPTER (INNER ALUM.)	1 1/4"	ROUND	CNC	0101	39.95	01511	8.00
12A	CRATE MOTOR/FASTBURN-LT1/LT4	1 5/8"	D	CNC	0103	29.95	01560	8.00
*12A	CRATE MOTOR/FASTBURN-LT1/LT4	1 5/8"	D	CNC	*0103-5	39.95	01560	8.00
12A	CRATE MOTOR/FASTBURN-LT1/LT4	1 3/4"	D	CNC	0104	29.95	01560	8.00
*12A	CRATE MOTOR/FASTBURN-LT1/LT4	1 3/4"	D	CNC	*0104-5	39.95	01560	8.00
11A	STANDARD SB (LITE) 265-400	1 3/4"	OVAL	CNC	0106	29.95	01510	8.00
11A	STANDARD SB (LITE) 265-400	1 7/8"	REC	CNC	0107	29.95	01510	8.00
23A	STANDARD SB 265-400	1 1/2"	ROUND	CNC	01091	29.95	01500	8.00
32A	STANDARD SB 265-400	1 5/8"	SQUARE	CNC	01101	29.95	01501	8.00
*32A	STANDARD SB 265-400	1 5/8"	SQUARE	CNC	*01101-5	39.95	01501	8.00
----	BRODIX TRACK 1/SPEC. HEAD	1 5/8"	SAP	CNC	01105	29.95	01570	8.50
24A	STANDARD SB 265-400	1 3/4"	D	CNC	01111	29.95	01511	8.00
*24A	STANDARD SB 265-400	1 3/4"	D	CNC	*01111-5	39.95	01511	8.00
----	STANDARD SB 265-400	1 3/4"	OVAL	----	----	----	01510	8.00
24A	STANDARD SB 265-400	1 7/8"	REC	CNC	0112	29.95	01510	8.00
14A	SB 18° DEGREE/ PRO ACTION 14°- 6 BOLT	1 3/4"	SAP	CNC	0115	29.95	01540	9.50
*14A	SB 18° DEGREE/ PRO ACTION 14°- 6 BOLT	1 3/4"	SAP	CNC	*0115-5	39.95	01540	9.50
14A	SB 18° DEGREE/ PRO ACTION 14°- 6 BOLT	1 7/8"	SAP	CNC	0116	29.95	01540	9.50
*14A	SB 18° DEGREE/ PRO ACTION 14°- 6 BOLT	1 7/8"	SAP	CNC	*0116-5	39.95	01540	9.50
14A	SB 18° DEGREE/ PRO ACTION 14°- 6 BOLT	2"	SAP	CNC	0117	29.95	01540	9.50
*14A	SB 18° DEGREE/ PRO ACTION 14°- 6 BOLT	2"	SAP	CNC	*0117-5	39.95	01540	9.50
8A	SB BRODIX SPREAD PORT(X)	1 3/4"	D	CNC	0119	29.95	01533	9.50
8A	SB BRODIX SPREAD PORT(X)	1 7/8"	D	CNC	0120	29.95	01533	9.50
10A	SB SPREAD PORT (LITE)(X)	1 3/4"	D	CNC	0121	29.95	01533	9.50
10A	SB SPREAD PORT (LITE)(X)	1 7/8"	D	CNC	0122	29.95	01532	9.50
10A	SB SPREAD PORT (LITE)(X)	2"	ROUND	CNC	0123	29.95	01531	9.50
29A	BRODIX ASCS/SUPRA	1 3/4"	SAP	CNC	01191	29.95	01530	9.50
30A	SB DOWN NOZZLE (SPREAD PORT)	1 7/8"	D	CNC	01251	29.95	01531	9.50
16A	SB DOWN NOZZLE (SPREAD PORT)	2"	ROUND	CNC	0126	29.95	01531	9.50
16A	SB DOWN NOZZLE (SPREAD PORT)	2 1/8"	ROUND	CNC	0127	29.95	01531	9.50
31A	SB DOWN NOZZLE ALL PRO - GB23/24	1 7/8"	SAP	CNC	01850	29.95	01532	9.50
31A	SB DOWN NOZZLE ALL PRO - GB23/24	2"	SAP	CNC	01860	29.95	01532	9.50
17A	SB ALAN JOHNSON 18 DEGREE	1 7/8"	ROUND	CNC	0130	29.95	----	----
17A	SB ALAN JOHNSON 18 DEGREE	2"	ROUND	CNC	0131	29.95	----	----
18A	SB 18° (OUTER, HOOKER ADAPTER)	1 7/8"	ROUND	CNC	0133	29.95	----	----
18A	SB 18° (OUTER, HOOKER ADAPTER)	2"	ROUND	CNC	0134	29.95	----	----
19A	SB SB2	1 7/8"	SAP	CNC	0135	29.95	01590	11.50
19A	SB SB2	2"	SAP	CNC	0136	29.95	01590	11.50
20A	SB PONTIAC HEAD (7 BOLT) # 867	1 3/4"	SAP	CNC	0142	29.95	----	----
20A	SB PONTIAC HEAD (7 BOLT) # 867	1 7/8"	SAP	CNC	0143	29.95	----	----

Tractor/Derby
 Crossover
 180° Crossover
 Street Stock
 Stock Clip
 Flanges/Gaskets
 Collectors
 Drag
 4 Cyl.
 Dirt Mod.
 Chassis
 IMCA Mod.
 X & Y Pipes
 Turnouts & Extensions
 U & J Bends
 Sprint
 Midget
 Applications
 Misc.
 Elbow Applications



479-474-7529
 Fax # 479-474-2249
 Van Buren, AR
 www.SchoenfeldHeaders.com

Tractor/Derby
 4 Cyl. Drag
 Collectors
 180° Crossover
 Stock Clip
 Street Stock
 U & J Bends
 Chassis
 IMCA Mod.
 Turnouts & Extensions
 Misc.
 Midget
 Chassis Applications
 Elbow Applications
 Mufflers

Flanges price per each
 SAP = Same as port
 * = 5/16" thick

(Small Block Chevy Cont.)

REF#	CYLINDER HEAD DESCRIPTION	TUBE DIA.	PORT SHAPE	STAMP/ CNC	FLANGE PART #	FLANGE PRICE	GASKET PART #	GASKET PRICE
21A	SB STAHL (OUTER FLANGE)	1 3/4"	ROUND	CNC	0148	29.95	0152	9.50
21A	SB STAHL (OUTER FLANGE)	1 7/8"	ROUND	CNC	0144	29.95	0152	9.50
21A	SB STAHL (OUTER FLANGE)	2"	ROUND	CNC	0145	29.95	0152	9.50
21A	SB STAHL (OUTER FLANGE)	2 1/8"	ROUND	CNC	0146	29.95	0152	9.50
22A	SB 18° BRODIX SPREAD PORT(C)	1 7/8"	SAP	CNC	0161	29.95	01530	9.50
15A	SB 18° DART (Dual Bolt Pattern)	1 7/8"	SAP	CNC	0164	29.95	01540	9.50
15A	SB 18° DART (Dual Bolt Pattern)	2"	SAP	CNC	0165	29.95	01540	9.50
25A	SBC BRODIX (BD)	1 7/8"	ROUND	CNC	0167	29.95	----	----
25A	SBC BRODIX (BD)	2"	ROUND	CNC	0168	29.95	----	----
25A	SBC BRODIX (BD)	2 1/8"	ROUND	CNC	0169	29.95	----	----
26A	SBC PRO-ACTION 23°	1 7/8"	SAP	CNC	0175	29.95	01511	8.00
*27A	SBC LS1-LS7	1 5/8"	ROUND	CNC	*0177	39.95	01780	10.50
*27A	SBC LS1-LS7	1 3/4"	ROUND	CNC	*0178	39.95	01780	10.50
*27A	SBC LS1-LS7	1 7/8"	ROUND	CNC	*0179	39.95	01780	10.50
28A	SBC PRO-ACTION 14° - 7 BOLT	1 7/8"	SAP	CNC	0181	29.95	----	----

Big Block & 6 Cylinder Chevy

* = 5/16" thick

REF#	CYLINDER HEAD DESCRIPTION	TUBE DIA.	PORT SHAPE	STAMP/ CNC	FLANGE PART #	FLANGE PRICE	GASKET PART #	GASKET PRICE
*30B	BB 396-454	1 5/8"	ROUND	CNC	*0208	39.95	0250	9.50
*30B	BB 396-454	1 7/8"	ROUND	CNC	*0210	39.95	02510	9.50
*30B	BB 396-454	2"	SAP	CNC	*0211	39.95	02510	9.50
*30B	BB 396-454	2 1/8"	ROUND	CNC	*0212	39.95	02520	9.50
*30B	BB 396-454	2 1/4"	ROUND	CNC	*0213	39.95	02520	9.50
31B	V-6 18 DEGREE	1 3/4"	SAP	CNC	0830	29.95	----	----
31B	V-6 18 DEGREE	1 7/8"	SAP	CNC	0832	29.95	----	----
32B	V-6 STANDARD	1 5/8"	SAP	CNC	08311	29.95	08341	10.50
32B	V-6 STANDARD	1 3/4"	OVAL	CNC	08330	29.95	08341	10.50

Big Block Ford

* = 5/16" thick

REF#	CYLINDER HEAD DESCRIPTION	TUBE DIA.	PORT SHAPE	STAMP/ CNC	FLANGE PART #	FLANGE PRICE	GASKET PART #	GASKET PRICE
*37C	429-460 FORD	1 7/8"	SAP	CNC	*0611	39.95	06511	9.50
*37C	429-460 FORD	2"	SAP	CNC	*0612	39.95	06511	9.50
*37C	429-460 FORD	2 1/8"	SAP	CNC	*0613	39.95	06511	9.50
*37C	429-460 FORD COBRA	2 1/8"	SAP	CNC	*0613C	39.95	06511	9.50

V-6 & 4 Cylinder Ford & Toyota

REF#	CYLINDER HEAD DESCRIPTION	TUBE DIA.	PORT SHAPE	STAMP/ CNC	FLANGE PART #	FLANGE PRICE	GASKET PART #	GASKET PRICE
38D	SVO RACING HEAD (ALUM.) V-6	1 3/4"	SAP	CNC	0630	29.95	----	----
39D	2000cc (4 CYLINDER)	1 1/2"	OVAL	CNC	FF20	29.95	FG20	10.50
39D	2000cc (4 CYLINDER)	1 5/8"	OVAL	CNC	FF21	29.95	FG20	10.50
40D	2300cc (4 CYLINDER)	1 1/2"	OVAL	CNC	FF23	29.95	FG23	10.50
40D	2300cc (4 CYLINDER)	1 5/8"	OVAL	CNC	FF24	29.95	FG23	10.50
*41D	TOYOTA V-8	1 7/8"	SAP	CNC	*TF41	39.95	----	----



Small Block Ford

33E		34E		35E		36E			
37E		38E		39E		40E			
41E									
REF#	CYLINDER HEAD DESCRIPTION	TUBE DIA.	PORT SHAPE	STAMP/ CNC	FLANGE PART #	FLANGE PRICE	GASKET PART #	GASKET PRICE	
33E	289W - 351W / GT40	1 5/8"	SAP	CNC	0306	29.95	03500	9.50	
33E	289W - 351W / GT40	1 3/4"	SAP	CNC	0309	29.95	03500	9.50	
34E	SVO "N" / DART WIDE BOLTS	1 5/8"	SAP	CNC	0311	29.95	03520	9.50	
34E	SVO "N" / DART WIDE BOLTS	1 3/4"	SAP	CNC	0312	29.95	03520	9.50	
41E	BRODIX CNC / STS T1	1 5/8"	SAP	CNC	03155	29.95	03520	9.50	
41E	BRODIX CNC / STS T1	1 3/4"	SAP	CNC	03156	29.95	03520	9.50	
41E	BRODIX CNC / STS T1	1 7/8"	SAP	CNC	03157	29.95	03520	9.50	
34E	EDELBROCK/MCGUNEGILL	1 3/4"	SAP	CNC	03151	29.95	03520	9.50	
34E	EDELBROCK	1 7/8"	SAP	CNC	0316	29.95	03520	9.50	
39E	EDELBROCK / KUNTZ	1 7/8"	SAP	CNC	0318	29.95	----	----	
40E	CRATE MOTOR/Z304	1 5/8"	SAP	CNC	0320	29.95	03520	9.50	
40E	CRATE MOTOR/Z304	1 3/4"	SAP	CNC	0321	29.95	03520	9.50	
35E	351 CLEVELAND (2 BARREL) 351	1 3/4"	OVAL	STAMP	0510	29.95	----	----	
36E	CLEVELAND (4 BARREL) SVO	2"	SAP	CNC	0512	29.95	----	----	
37E	SVO C3/C33 YATES (ALUM.)	1 7/8"	SAP	CNC	0602	29.95	----	----	
38E	SVO D3 YATES (ALUM.)	1 7/8"	ROUND	CNC	0603	29.95	----	----	

Mopar

47F		48F		49F		50F			
51F		52F		53F		54F			
55F		56F		57F		58F			
REF#	CYLINDER HEAD DESCRIPTION	TUBE DIA.	PORT SHAPE	STAMP/ CNC	FLANGE PART #	FLANGE PRICE	GASKET PART #	GASKET PRICE	
58F	W-9 RAISED INTAKE (LITE)	1 7/8"	SAP	CNC	0404	29.95	----	----	
58F	W-9 RAISED INTAKE (LITE)	2"	ROUND	CNC	0405	29.95	----	----	
50F	273-318-340-360	1 5/8"	SAP	CNC	0410	29.95	04500	9.50	
50F	273-378-340-360	1 3/4"	SAP	CNC	0411	29.95	04500	9.50	
51F	W-2 (4 3/4" CNTR. BOLTS)	1 3/4"	D	CNC	0414	29.95	----	----	
52F	W-2 (4" OR 4 3/4" CNTR. BOLTS)	1 5/8"	OVAL	CNC	0417	29.95	----	----	
52F	W-2 (4" OR 4 3/4" CNTR. BOLTS)	1 3/4"	OVAL	CNC	0418	29.95	----	----	
53F	W-5	1 3/4"	SAP	CNC	0420	29.95	----	----	
54F	W-7	1 7/8"	SAP	CNC	0423	29.95	----	----	
56F	W-9	1 7/8"	ROUND	CNC	0407	29.95	----	----	
56F	W-9	2"	SAP	CNC	0408	29.95	----	----	
47F	W-9 (LITE)	1 7/8"	SAP	CNC	0455	29.95	----	----	
57F	W-9 (LITE)	2"	SAP	CNC	0426	29.95	----	----	
55F	440 WEDGE (INDY)	1 7/8"	SAP	CNC	0427	29.95	----	----	
55F	440 WEDGE (INDY)	2"	SAP	CNC	0428	29.95	----	----	
55F	440 WEDGE (INDY)	2 1/8"	SAP	CNC	0430	29.95	----	----	
55F	440 WEDGE (INDY)	2 1/4"	SAP	CNC	0431	29.95	----	----	
48F	MAGNUM CRATE MOTOR	1 5/8"	SAP	CNC	0432	29.95	----	----	
55F	440 IRON	1 3/4"	SAP	CNC	0434	29.95	----	----	
55F	440 IRON	1 7/8"	SAP	CNC	0435	29.95	----	----	
55F	440 IRON	2"	SAP	CNC	0436	29.95	----	----	
49F	MOPAR W2 (B1/BA-ASCS)	1 3/4"	OVAL	CNC	0441	29.95	----	----	

Tractor/Derby
 Crossover
 180° Crossover
 Street Stock
 Stock Clip
 Chassis
 IMCA Mod.
 Dirt Late Model
 Sprint
 Midget
 Applications
 Misc.
 Turnouts & Extensions
 X & Y Pipes
 U & J Bends
 Flanges/Gaskets
 Collectors
 Drag
 4 Cyl.
 Dirt Mod.

Reducers

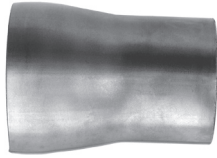

Header Bolts

NEW 5/16" Head

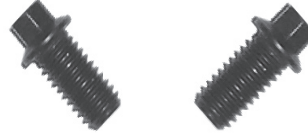

INSIDE DIAMETER	OUTSIDE DIAMETER	PART #	PRICE
3" I.D.	2 1/2" O.D.	2530	7.95
3 1/2" I.D.	2 1/2" O.D.	2535	9.95
3 1/2" I.D.	3" O.D.	3035	8.95
3" I.D.	3 1/2" O.D.	3530	8.95
4" I.D.	3 1/2" O.D.	4035	9.95
3" I.D.	3" O.D.	3030	8.95
3 1/2" I.D.	3 1/2" O.D.	3535	8.95

DESCRIPTION	PART #	PRICE
3/8" x 3/4" x 5/16" HEX HEAD, 12 PACK	3006-12	7.35
3/8" x 3/4" x 5/16" HEX HEAD, 14 PACK	3006-14	8.20
3/8" x 3/4" x 5/16" HEX HEAD, 16 PACK	3006-16	9.10
3/8" x 3/4" FLAT HEAD, 12 PACK	3001-12	9.00
3/8" x 1" x 5/16" HEX HEAD, 12 PACK	3002-12	11.70
5/16" x 3/4" x 3/8" HEX HEAD (MOPAR) - 12 PACK	3003-12	9.60
8mm x 20mm (LS1-LS7) 12 PACK	3004-12	9.20
8mm x 20mm (2000 PINTO) 8 PACK	3004-8	7.40
10mm x 22mm (2300 PINTO) 8 PACK	3005-8	7.40

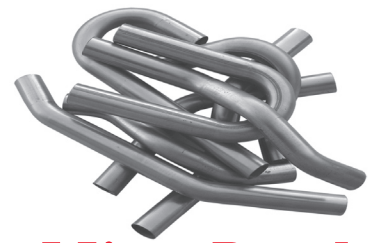

U & J Mandrel Bends

18 GAUGE TUBING					16 GAUGE TUBING		
U BENDS #	J BENDS #	PRICE	TUBE DIA.	BEND RADIUS	U BENDS #	J BENDS #	PRICE
013718U	013718J	11.00	1 3/8"	2 1/2"	013716U	013716J	13.00
----	----	----	1 1/2"	2 1/2"	015016U	015016J	13.00
016218U	016218J	11.00	1 5/8"	2 1/2"	016216U	016216J	13.00
017518U	017518J	11.00	1 3/4"	2 1/2"	017516U	017516J	13.00
018718U	018718J	11.00	1 7/8"	3"	018716U	018716J	13.00
018718U-40	018718J-40	11.00	1 7/8"	4"	----	----	----
020018U	020018J	12.00	2"	3"	----	----	----
020018U-40	020018J-40	12.00	2"	4"	----	----	----
021218U	021218J	13.00	2 1/8"	3"	----	----	----
021218U-35	021218J-35	13.00	2 1/8"	3 1/2"	----	----	----
022518U	022518J	14.00	2 1/4"	3 1/2"	----	----	----
023718U	023718J	18.00	2 3/8"	3 1/2"	----	----	----

Misc. Bends

Approx. 36 Ft.
 18ga. Mild Steel
 MB150 16ga.

TUBE DIA.	PART #	PRICE
1 3/8"	MB137	159.95
1 1/2"	MB150	159.95
1 5/8"	MB162	159.95
1 3/4"	MB175	159.95
1 7/8"	MB187	169.95
2"	MB200	179.95
2 1/8"	MB212	199.95
2 1/4"	MB225	209.95
2 3/8"	MB237	219.95

U Bends have 9" legs & J Bends have 3" and 15" legs (Straight Part) -- 2 1/4" U Bends have 7 1/2" legs

O2 Bung

BUNG PART #	BUNG PRICE EA.	SIZE
100-14	6.00	18 mm



INSTALLED

BUNG PART #	BUNG PRICE SET	SIZE
100-15	40.00	18 mm



Flanges & Gaskets

FLANGE PART #	FLANGE PRICE	FLANGE ID.	BOLT HOLES	GASKET PART #	GASKET PRICE
250CR	3.75	2 1/2"	3	250CG	5.00
300CR	3.75	3"	3	300CG	5.00
350CR	4.00	3 1/2"	3	350CG	5.00



Collectors



SLIPS OVER	COLL DIA.	# OF TUBES	STYLE 3 PART #	STYLE 6 PART #	STYLE 8 PART #	STYLE 9 PART #	STYLE 9H #	STYLE 6 ROTATED #	STYLE 8 ROTATED #	PRICE
1 1/2"	3"	4	SO53043	SO53046	SO53048	SO53049	SO53049H	SO53046R	SO53048R	36.95
1 5/8"	3"	4	SO63043	SO63046	SO63048	SO63049	SO63049H	SO63046R	SO63048R	36.95
1 5/8"	3 1/2"	4	SO63543	SO63546	SO63548	SO63549	SO63549H	SO63546R	SO63548R	36.95
1 3/4"	3 1/2"	4	SO73543	SO73546	SO73548	SO73549	SO73549H	SO73546R	SO73548R	36.95
1 7/8"	3 1/2"	4	SO83543	SO83546	SO83548	SO83549	SO83549H	SO83546R	SO83548R	36.95



*Style 2

SLIP-OVER



Style 1



WELD-ON

*-2 PART #	-2 PRICE	-1 PART #	-1 PRICE	SLIPS OVER	COLL. DIA.	# OF TUBES	PART #	COLL. LEN.	PRICE
----	----	ASK	38.95	1 1/2"	3"	3	WO53030	8"	14.00
----	----	ASK	38.95	1 5/8"	3"	3	WO63030	8"	14.00
----	----	ASK	38.95	1 3/4"	3"	3	WO73030	8"	14.00
----	----	ASK	38.95	1 7/8"	3"	3	WO83030	8"	14.00
----	----	ASK	38.95	2"	3"	3	WO03030	8"	14.00
----	----	SO53041	38.95	1 1/2"	3"	4	WO53040	8"	14.00
SO63042	43.95	SO63041	38.95	1 5/8"	3"	4	WO63040	8"	14.00
SO73042	43.95	SO73041	38.95	1 3/4"	3"	4	WO73040	8"	14.00
SO63542	43.95	SO63541	38.95	1 5/8"	3 1/2"	4	WO63540	8"	14.00
SO73542	45.95	SO73541	38.95	1 3/4"	3 1/2"	4	WO73540	8"	15.00
SO83542	45.95	SO83541	38.95	1 7/8"	3 1/2"	4	WO83540	9"	16.00
SO03542	45.95	SO03541	42.95	2"	3 1/2"	4	WO03540	9"	16.00
----	----	----	----	2 1/8"	3 1/2"	4	WO13540	9"	19.95
----	----	SO04041	44.95	2"	4"	4	WO04040	10"	19.95
----	----	SO14041	45.95	2 1/8"	4"	4	WO14040	10"	20.95
----	----	----	----	2 1/4"	4"	4	WO24040	10"	21.95

New! Merge Collectors

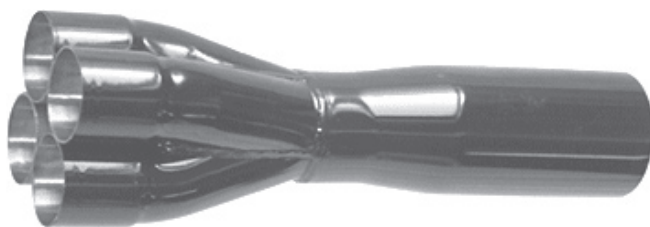

SLIPS OVER	MERGE DIAMETER	OUTLET DIAMETER	PART #	PRICE
1 3/4"	2 1/2"	3"	SOM72530	209.95
1 7/8"	2 1/2"	3"	SOM82530	209.95
2"	2 1/2"	3"	SOM02530	209.95
1 3/4"	2 3/4"	3 1/2"	SOM72735	209.95
1 7/8"	2 3/4"	3 1/2"	SOM82735	209.95
2"	2 3/4"	3 1/2"	SOM02735	209.95
2 1/8"	2 3/4"	3 1/2"	SOM12735	219.95
2 1/4"	2 3/4"	3 1/2"	SOM22735	219.95
2 3/8"	3 1/2"	4"	SOM33540	239.95

Tractor/Derby
 Dirt Mod.
 Crossover
 Drag 4 Cyl.
 Collectors
 180° Crossover
 Flanges/Gaskets
 Stock Clip
 Street Stock
 U & J Bends
 Chassis
 X & Y Pipes
 Turnouts & Extensions
 Misc.
 Midget
 Elbow Applications
 Chassis Applications
 Mufflers

Collector Numbering System

COLL. TYPE		*SLIP OVER		COLL DIA.		# OF TUBES		COLL. STYLE	
SLIP-ON	SO	1 1/2"	5	3"	30	6 CYL.	3	WELD-ON	0
WELD-ON	WO	1 5/8"	6	3 1/2"	35	8 CYL.	4	STYLE 1	1
		1 3/4"	7	4"	40			STYLE 2	2
		1 7/8"	8					30°	3
		2"	0					60°	6
		2 1/8"	1					60° ROTATED	6R
		2 1/4"	2					90° INSIDE	8
								90° ROTATED	8R
								90° OUTSIDE	9
								90° HARRIS	9H

Example: **SO63049H**

*Indicates tube diameter the collector slips over.

2 Into 1 Y Pipes (Collectors)



2 Into 1 Y Pipe 60°



2 Into 1 Y Pipe

SLIPS OVER	COLL. DIA.	ANGLE	PART #	PRICE
1 5/8"	1 7/8"	----	Y16S1818	89.95
1 3/4"	2"	----	Y17S2020	89.95
1 7/8"	2 1/8"	----	Y18S2121	89.95
1 7/8"	2 1/2" - 3"	----	Y18S2530	99.95
2"	2 1/4"	----	Y20S2222	89.95
2"	2 1/2" - 3"	----	Y20S2530	99.95
2"	2 1/2" - 3"	60°	Y20S2530-60	129.95
2 1/8"	2 1/2"	----	Y21S2525	89.95
2 1/8"	2 1/2" - 3"	----	Y21S2530	99.95
2 1/8"	2 1/2" - 3"	60°	Y21S2530-60	129.95
2 1/8"	2 3/4" - 3 1/2"	----	Y21S2735	99.95
2 1/8"	2 3/4" - 3 1/2"	60°	Y21S2735-60	129.95
2 1/4"	2 1/2" - 3"	----	Y22S2530	99.95
2 1/4"	2 1/2" - 3"	60°	Y22S2530-60	129.95
2 1/4"	2 3/4" - 3 1/2"	----	Y22S2735	99.95
2 1/4"	2 3/4" - 3 1/2"	60°	Y22S2735-60	129.95
2 1/2"	2 3/4" - 3 1/2"	----	Y25S2735	99.95
2 1/2"	2 3/4" - 3 1/2"	60°	Y25S2735-60	129.95

479-474-7529
 Fax # 479-474-2249
 Van Buren, AR
 www.SchoenfeldHeaders.com



Tab Kits



Tab kits include Tabs, Bolts, Lock Nuts and Washers. (except 4001-12)

PART #	DESCRIPTION	PRICE
4003-1	2 TABS/1 BOLT/1 LOCK NUT/2 WASHERS	4.50
4003-2	4 TABS/2 BOLTS/2 LOCK NUTS/4 WASHERS	7.95
4003-4	8 TABS/4 BOLTS/4 LOCK NUTS/8 WASHERS	13.95
4003-6	12 TABS/6 BOLTS/6 LOCK NUTS/12 WASHERS	17.95
4000-6	6 BOLTS/6 LOCK NUTS/12 WASHERS	5.95
4001-12	12 TABS (TABS ONLY)	15.00

Exhaust Elbows

DIAMETER	ANGLE°	CLR	A LENGTH	B LENGTH	PART #	PRICE
2 1/2"	45°	5 1/4"	6 1/2"	5"	2545	23.95
2 1/2"	90°	5 1/4"	5 3/4"	5 3/4"	2590	23.95
3"	30°	5"	6 1/2"	6 3/4"	3031	23.95
3"	30°	5"	15 1/2"	6"	3032	23.95
3"	42°	5"	10"	10"	3042	23.95
3"	45°	5"	5"	6"	3045	23.95
3"	60°	5"	5"	6"	3060	23.95
3"	80°	5"	4 1/2"	4 1/2"	3080	23.95
3"	80°	5"	1 5/8"	5"	3081	23.95
3"	90°	5"	4 1/2"	4 1/2"	3090	23.95
3 1/2"	30°	5"	6 1/4"	6"	3531	23.95
3 1/2"	30°	5"	15 1/2"	6"	3532	23.95
3 1/2"	42°	5"	10"	10"	3542	23.95
3 1/2"	45°	5"	6 1/2"	3 1/2"	3545	23.95
3 1/2"	60°	5"	6"	1 1/2"	3560	23.95
3 1/2"	80°	5"	5 1/4"	2 3/4"	3580	23.95
3 1/2"	90°	5"	5 1/4"	2 3/4"	3590	23.95
4"	45°	6"	6 1/2"	8 1/2"	*4045	32.95
4"	90°	6"	3"	3"	*4090	32.95
5"	45°	6"	6"	6"	5045	45.95
5"	90°	5"	1 1/2"	1 1/2"	5090	45.95

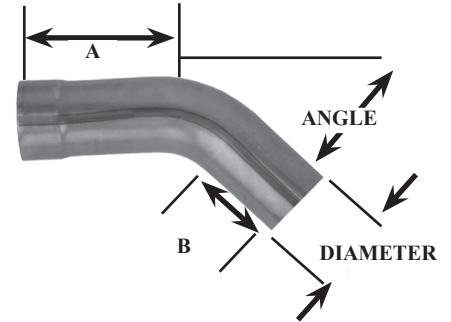

CLR = Center Line Radius*
 All elbows and turn outs are expanded on A end

Turn Outs

SIZE	LENGTH	PART #	PRICE
2 1/2"	10"	2525	18.95
3"	4 1/4"	3023	18.95
3"	10"	3025	18.95
3"	15 1/2"	3026	21.95
3 1/2"	4 1/2"	3523	18.95
3 1/2"	10"	3525	18.95
4"	10 1/2"	*4025	26.95
5"	12"	5025	39.95

*Aluminized



Extensions



LENGTH	2 1/2" DIA. #	PRICE	3" DIA. #	PRICE	3 1/2" DIA. #	PRICE	4" DIA. #	PRICE	5" DIA. #	PRICE
12"	120025	10.95	120030	10.95	120035	10.95	120040	14.95	120050	21.95
24"	240025	12.95	240030	12.95	240035	13.95	240040	19.95	240050	30.95
30"	300025	14.95	300030	14.95	300035	15.95	300040	22.95	-----	-----
36"	360025	15.95	360030	15.95	360035	16.95	360040	26.95	360050	45.95
48"	480025	18.95	480030	18.95	480035	18.95	480040	33.95	480050	62.95

*All extensions are expanded on one end

Insert Reducers

COLLECTOR DIAMETER	LENGTH	CORE DIAMETER	PART #	PRICE
3"	4"	2 1/2"	42530NH	15.95
3 1/2"	4"	2 1/2"	42535NH	15.95
3 1/2"	4"	3"	43035NH	15.95
4"	4"	3 1/2"	43540NH	20.95



Inserts into collector to increase lower end torque

Chassis Applications | Midget | Sprint | Dirt Late Model | IMCA Mod. | Chassis | Street Stock | Stock Clip | 180° Crossover | Tractor/Derby
 Mufflers | Elbow Applications | Misc. | Turnouts & Extensions | X & Y Pipes | U & J Bends | Flanges/Gaskets | Collectors | Drag | 4 Cyl. | Dirt Mod.

Exhaust System Applications

2 x 1 Collectors

INLET DIA.	3" OUT #	3 1/2" OUT #	4" OUT #	5" OUT #	PRICE
3" I.D.	Y3030	Y3035	Y3040	Y3050	99.95
3 1/2" I.D.	-----	Y3535	Y3540	Y3550	99.95

2 x 2 Collectors

INLET DIA.	2 1/2" OUT #	3" OUT #	3 1/2" OUT #	PRICE
2 1/2" I.D.	X2525	-----	-----	159.95
3" I.D.	-----	X3030	X3035	159.95
3 1/2" I.D.	-----	X3530	X3535	159.95



Right Side Elbow
(See Chart Below)



Left Side Elbow
(See Chart Below)



2x2 and 2x1 collectors are designed for easy muffler and tailpipe installation.

Tail Pipe Saver

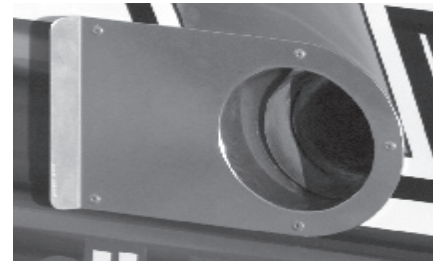

Crossover style headers as listed on page 3.
(Elbows, 2x2 and 2x1 collectors not included with headers.)

New! Visit website for details

For Mufflers, See Page 46

HEADER STYLE	LEFT SIDE #	PRICE	RIGHT SIDE #	PRICE	TOTAL PRICE
134V, 134VH, 135, 135V-3, 135H, 335	3042	23.95	3031	23.95	47.90
135VY, 135VYCM, 335VY, 335VYE	1-30310	23.95	1-30310	23.95	71.85
	1-3045	23.95			
135V, 135VH, 136, 136V, 136VH, 335V, 336	3542	23.95	3531	23.95	47.90
136V3Y, 336V3Y	1-35310	23.95	1-35310	23.95	71.85
	1-3545	23.95			
145, 445	3032	23.95	3031	23.95	47.90
145V, 146, 146V, 445V, 446	3532	23.95	3531	23.95	47.90
179-1	480030	18.95	480030	18.95	37.90
179V-1, 180-1	480035	18.95	480035	18.95	37.90
179-2	360030	15.95	360030	15.95	29.90
179V-2, 180-2	360035	16.95	360035	16.95	31.90
D180, D180V, H180, H180V	1-3535	8.95	1-3545	23.95	65.80
	1-3545	23.95			



Mufflers

LENGTH	OUTLET DIAMETER	INLET DIAMETER	BODY DIAMETER	PART #	PRICE
6"	3"	3"	3 1/2"	63030	15.95
8"	3"	3"	3 1/2"	83030	15.95
12"	3"	3"	3 1/2"	123030	22.95
6"	3 1/2"	3 1/2"	4"	63535	15.95
8"	3 1/2"	3 1/2"	4"	83535	15.95
8"	3 1/2"	4"	4"	83540	23.95
9"	3 1/2"	3 1/2"	4 3/8"	92535	35.95
10"	3 1/2"	3 1/2"	4"	103535K	35.95
12"	3 1/2"	3 1/2"	4"	123535	26.95
12"	3 1/2"	4"	4"	123540	27.95
12"	4"	4"	4"	124040	26.95
14"	3 1/2"	3 1/2"	4 1/2"	14272535	69.95
14"	3 1/2"	3 1/2"	4 1/2"	14272735-78	69.95
18"	3 1/2"	3 1/2"	4"	183535	30.95
24"	3 1/2"	3 1/2"	4"	243535	38.95
27"	4"	4"	4 1/2"	273540	64.95

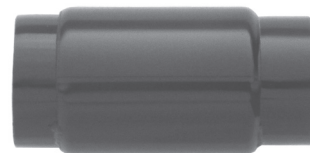

95 DB Muffler
 At 4 pounds



LENGTH	WEIGHT	PART #	PRICE	SANCTION APPROVED
11"	2.84#	112535	35.95	ALL-STAR - SUPRA
11"	2.35#	112530	35.95	-----
11"	2.40#	113035	35.95	-----
14"	4.00#	14272735-78	69.95	W.O.O - ASCS

IMCA Mufflers

LENGTH	WEIGHT	PART #	PRICE	SANCTION APPROVED
6"	1.28#	IMCA609	35.95	IMCA
9"	1.95#	IMCA930	35.95	IMCA
9"	2.30#	IMCA935	35.95	IMCA

New!
New!

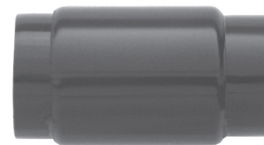

Insert Muffler

With its straight through design, the Schoenfeld Insert Muffler reduces noise without excess back pressure. The insert is light weight with nothing to burn out.

COLLECTOR DIAMETER	LENGTH	CORE DIAMETER	PART #	PRICE
3"	4"	2 1/2"	42530	14.95
3 1/2"	4"	3"	43035	14.95
4"	4"	3 1/2"	43540	19.95
3 1/2"	24"	3"	243035	33.95
4"	24"	3"	243040	33.95
4"	24"	3 1/2"	243540	35.95
3 1/2"	30"	3"	303035	37.95
4"	30"	3"	303040	37.95
4"	30"	3 1/2"	303540	39.95

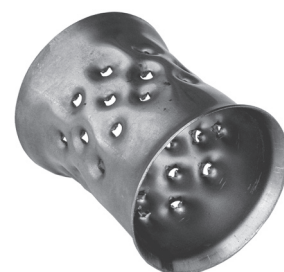

NEW!

Anti-Reversion Mufflers

NEW!

LENGTH	OUTLET DIAMETER	INLET DIAMETER	BODY DIAMETER	PART #	PRICE
11"	3 1/2"	3"	4"	112530AR	49.95
11"	3 1/2"	3 1/2"	4"	112535AR	49.95



FedEx Ground Shipping Schedule

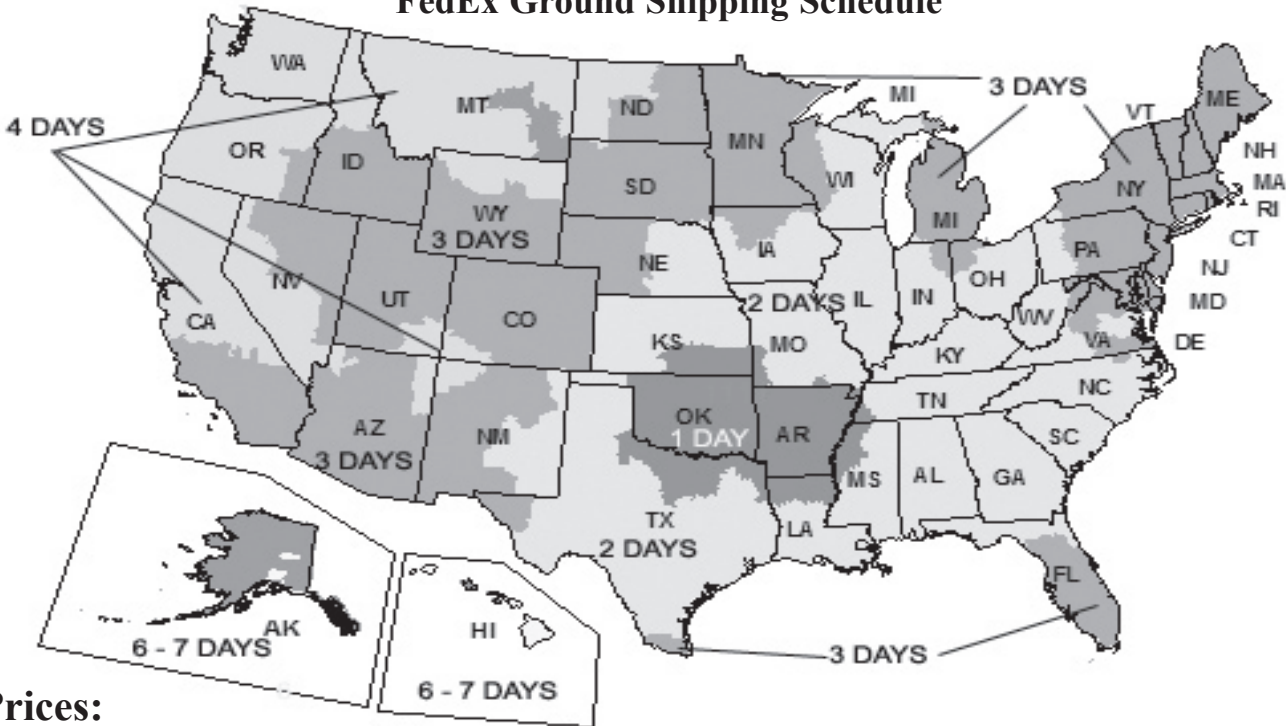

Prices:

All prices in this catalog are effective November 1st, 2014 and are subject to change without notice. Prices do not include shipping.

Shipping:

We ship FedEx Ground (preferable), motor freight and air freight.

Drop Shipment:

Drop Shipments will be charged a \$10.00 fee per order.

Returns:

All returns must be authorized with an RMA # and accompanied by a copy of the original invoice, with a note describing reason for return. The RMA # must be written on the box. Returns must be shipped pre-paid; no C.O.D. returns will be accepted. Any refused shipment returned to Schoenfeld Headers Inc., will be subject to a freight chargeback. Further orders will be delayed until charges are paid. No returns on special orders or obsolete parts.

SCHOENFELD *Headers*

Performance • Quality • Value

CONGRATULATIONS

2014

Champions

Thanks For Using Schoenfeld Headers

SCHOENFELD *Headers*

605 S. 40th St.
VAN BUREN, AR. 72956



Made in USA

www.SchoenfeldHeaders.com