

SCHOENFELD

Headers

Performance • Quality • Value



Don Schoenfeld (1st set of headers he ever built)

2024 RACING CATALOG

605 S. 40th St.
Van Buren, AR 72956
Ph: **479-474-7529**
Fax: 479-474-2249



Made in USA

www.SchoenfeldHeaders.com

INDEX

Small Block Chevy

Boat/Marine.....	22
Chassis.....	6
Crossover.....	3-5
Demolition Derby.....	38
Dirt Late Model.....	19-21
Dirt Late Model Tri-Y.....	19
D.I.R.T. Modified.....	35
Drag.....	7,9-11,36
IMCA-Modified.....	6,12-18
Midget.....	28
Sprint/Dyno.....	23-25
Sprint/Dyno Tri-Y.....	24
Street Stock/Stock Clip.....	6-11
Truck.....	36,37
Zoomie.....	5

LS1/LT1

LS1/LT1.....	5,23,35,36,37
LS1 Dirt Late Model Tri-Y.....	22

Big Block Chevy

Dyno/Sprint.....	23
Truck.....	37,38

Ford

2000cc & 2300cc.....	11
2000cc & 2300cc Tri-Y.....	11
Crossover.....	4
Demolition Derby.....	38
Dirt Late Model.....	22
Esslinger Midget.....	27
Focus Midget.....	29
IMCA-Modified.....	12,16,17
Sprint/Dyno.....	23,26
Street Stock.....	10
Truck.....	10,38

Mopar

Demolition Derby.....	38
Midget Merge.....	29
Sprint/Dyno.....	26
Truck.....	38

Micro Sprint

Yam.,Hon.,Kaw.,Suzuki.....	31-34
----------------------------	-------

Mod-Lite

Suzuki,Yam,Hon,Kaw.....	33
-------------------------	----

Gaskets & Flanges

SB Chevy.....	40,41
BB Chevy.....	41
Collector Rings.....	43
6 Cylinder Chevy.....	41
Ford.....	42
Mopar.....	43
Toyota.....	42

Miscellaneous

Applications (Chassis).....	39
Applications (Elbow).....	48
Bungs.....	43
Collectors.....	45,46
Elbows.....	47,48
Extensions.....	46,48
U & J Bends.....	44
Header Bolts.....	44
Merge Collectors.....	45
Misc. Bends.....	44
Mufflers.....	31-34,49-51
Reducers.....	44,50
Special Pricing.....	51
Tab Kits.....	47
Tail Pipe Savers.....	49
Turnouts.....	47
2x2 and 2x1 Collectors.....	48
2 Into 1 Y Pipes.....	46,48
Micro Mufflers.....	31-34

Conventional Crossover Tri-Y

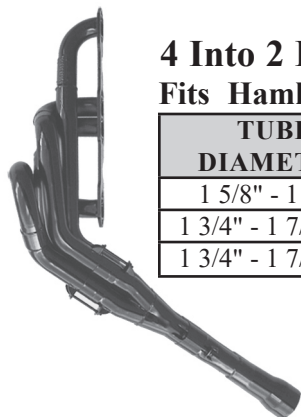

4 Into 2 Into 1 Tube Configuration for Increased Torque
 Fits Hamke, Howe, Lefthander, Pathfinder & Port City

TUBE DIAMETER	COLLECTOR DIA.	STANDARD CHEVY #	CRATE MOTOR #	CHEVY 18° #	PRICE
1 5/8" - 1 3/4"	3"	135VY	135VYCM	----	809.95
1 3/4" - 1 7/8" - 2"	3 1/2"	136V3Y	----	----	869.95
1 3/4" - 1 7/8" - 2"	3 1/2"	----	----	136V3Y18	929.95

For extension (elbow) applications see page 47-48

Fits Jerico Trans.
 Bolts and Gaskets included
 Comes With 5/16" Flange
 * = 604 Crate Motor
 Temporary non-high temperature paint

Conventional Crossover Headers

SB Chevy - Fits Bemco, Coleman, Hamke, Howe, Lefthander, Pathfinder and Port City

TUBE DIAMETER	COLLECTOR DIA./LENGTH	STANDARD CHEVY #	"H" STYLE #	CRATE MOTOR #	PRICE	CHEVY 18° #	PRICE
1 1/2" - 1 5/8"	3" x 8"	134V	134VH	----	369.95	----	----
1 5/8"	3" x 8"	135	135H	135CM2	309.95	----	----
1 5/8" - 1 3/4"	3 1/2" x 8"	135V	135VH	135VCM	369.95	----	----
1 5/8" - 1 3/4"	3" x 8"	135V-3	135VH-3	135VCM-3	369.95	----	----
1 3/4"	3 1/2" x 8"	136	136H	136CM	309.95	----	----
1 3/4" - 1 7/8"	3 1/2" x 9"	136V	136VH	136VCM	389.95	136V18	449.95
1 3/4" - 2"	3 1/2" x 9"	136V2	136V2H	----	409.95	136V218	469.95
1 3/4" - 1 7/8" - 2"	3 1/2" x 9"	136V3	----	----	449.95	136V318	509.95

H-style fits Howe, Port City, Statement and stock clip cars.
 (Different #7 cylinder)

Fits Jerico Trans.
 Available for GARC chassis
 CM2 = 602 Crate Motor
 CM = 604 Crate Motor



H Style



Bolts and Gaskets included

For extension (elbow) applications see page 47-48



Conventional Crossover Headers (cont.)

CNC laser cut flanges available to fit 18° Brodix spread port and Spread Port.

Dart, Pontiac 867 and Stahl pattern heads.

SB Chevy (will not fit Lefthander fab chassis)

TUBE DIAMETER	COLLECTOR DIA./LENGTH	STANDARD CHEVY #	CRATE MOTOR #	PRICE
1 1/2" - 1 5/8"	3" x 8"	144V	----	369.95
1 5/8"	3" x 8"	145	145CM2	309.95
1 5/8" - 1 3/4"	3 1/2" x 8"	145V	145VCM	369.95
1 5/8" - 1 3/4"	3" x 8"	145V-3	145VCM-3	369.95
1 3/4"	3 1/2" x 8"	146	146CM	309.95
1 3/4" - 1 7/8"	3 1/2" x 9"	146V	146VCM	389.95
1 3/4" - 1 7/8" - 2"	3 1/2" x 9"	146V3	----	449.95



CM = 604 Crate Motor
 CM2 = 602 Crate Motor

Ford Crossover

TUBE DIAMETER	COLLECTOR DIA./LENGTH	289-302-351 WINDSOR #	DART/"N" SPORTSMAN #	CRATE MOTOR #	PRICE
1 5/8"	3" x 8"	335	*335N	335CM	369.95
1 5/8" - 1 3/4"	3 1/2" x 8"	335V	*335VN	335VCM	429.95
1 5/8" - 1 3/4"	3" x 8"	335V-3	*335VN-3	335VCM-3	429.95
1 3/4"	3 1/2" x 9"	336	*336N	336CM	369.95
1 3/4" - 1 7/8"	3 1/2" x 9"	336V	*336VN	336VCM	449.95



(*Fits wide Dart bolt pattern and Sportsman "N" head)
 Available for Edelbrock
CM Fits Z304 Headed Crate motor
 Bolts and Gaskets included
 Temporary non-high temperature paint

Ford Tri Y Crossover

TUBE DIAMETER	COLLECTOR DIA.	289-302-351 WINDSOR #	DART/"N" SPORTSMAN #	EDLE/MCGUN #	PRICE
1 5/8" - 1 3/4"	3"	335VY	335VYN	335VYE	869.95
1 3/4" - 1 7/8" - 2"	3 1/2"	336V3Y	336V3YN	336V3YE	929.95



Temporary non-high temperature paint
 For extension (elbow) applications see page 47-48
 Bolts and Gaskets included
 Comes With 5/16" Flange

LS1-LS7 Crossover

SB Chevy - Fits Bemco, Coleman, Hamke, Howe, Lefthander and Port City

TUBE DIAMETER	COLLECTOR DIA./LENGTH	LS1-LS7 #	PRICE
1 5/8"	3" x 8"	135LS1	339.95
1 3/4"	3 1/2" x 8"	136LS1	339.95
1 3/4"	3" x 8"	136LS1-3	339.95
1 3/4" - 1 7/8"	3 1/2" x 9"	136VLS1	449.95



For extension (elbow) applications see page 47-48

Fits Jerico Trans.
 Bolts and Gaskets included
 Temporary non-high temperature paint

Chevy 180° Crossover



Exits thru lower right door.
 Uses 46" extension.

TUBE DIAMETER	COLLECTOR DIA./LENGTH	STANDARD CHEVY #	PRICE
1 5/8"	3" x 8"	179-1	339.95
1 5/8" - 1 3/4"	3 1/2" x 9"	179V-1	399.95
1 3/4"	3 1/2" x 9"	180-1	339.95

For extension (elbow) applications see page 47-48
 Bolts and Gaskets included
 Temporary non-high temperature paint

Zoomie Grassburner

Fits Chevy Late Model, IMCA type modified,
 Camaro, Chevelle, etc.



TUBE SIZE	STANDARD CHEVY #	PRICE
1 3/4"	130	149.95

Bolts and Gaskets included



Chevy Chassis Headers

Fits older Bullitt, GRT, Howe, NASCAR LMS, Shaw, and most IMCA Modifieds.
 Fits angle plug or straight plug heads, #1 spark plug needs to be at least 1" behind ball joint.

TUBE DIAMETER	COLLECTOR DIA./LENGTH	STANDARD CHEVY #	CRATE MOTOR #	PRICE	SPREAD PORT #	PRICE
1 5/8"	3" x 8"	*151	*151CM2	219.95	----	----
1 5/8" - 1 3/4"	3 1/2" x 8"	151V	151VCM	289.95	----	----
1 3/4"	3" x 8"	152-3	152CM-3	249.95	----	----
1 3/4"	3 1/2" x 8"	152	152CM	249.95	----	----
1 3/4" - 1 7/8"	3 1/2" x 9"	152V	152VCM	319.95	152VSP	379.95
1 7/8"	3 1/2" x 9"	153	----	309.95	153SP	369.95



Bolts and Gaskets included
 *NASCAR LMS Legal
 CM2 = 602 Crate Motor
 CM = 604 Crate Motor

151EL - 30" Primaries. Closer to equal length than 151 style.

TUBE DIAMETER	COLLECTOR DIA./LENGTH	STANDARD CHEVY #	CRATE MOTOR #	PRICE
1 5/8"	3" x 8"	*151E	*151ECM2	219.95
1 5/8"	3" x 8"	*151EL	*151ELCM2	259.95
1 3/4"	3" x 8"	152E-3	152ECM-3	249.95
1 3/4"	3 1/2" x 8"	152E	152ECM	249.95
1 3/4" - 1 7/8"	3 1/2" x 9"	152EV	152EVCM	319.95

151EL

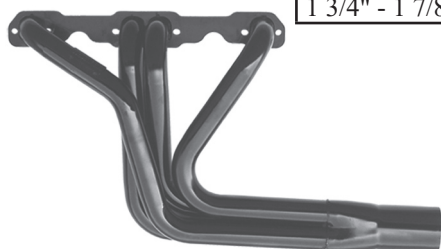

Bolts and Gaskets included
 *NASCAR LMS Legal
 CM2 = 602 Crate Motor
 CM = 604 Crate Motor
 Temporary non-high temperature paint

Ford Available
 151E

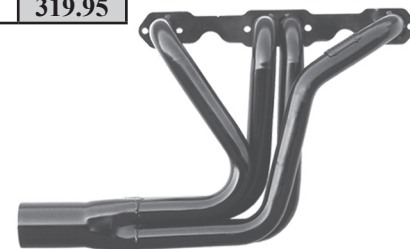

Chevy Stock Clip Header

Fits B & B 2020 and newer, Bigg Johnson, Cadillac, IROC, Medieval

TUBE DIAMETER	COLLECTOR DIA./LENGTH	STANDARD CHEVY #	CRATE MOTOR #	PRICE
1 5/8" - 1 3/4" - 1 7/8"	3" x 9"	197LBV3-3	197LBV3CM-3	449.95



Exits over frame rail. (Both sides)
 Bolts and Gaskets included
 Fits straight or angle plug heads.



Tractor/Derby
 Dirt Mod.
 4 Cyl. Drag
 Crossover
 180° Crossover
 Collectors
 Flanges/Gaskets
 Stock Clip
 Street Stock
 Chassis
 IMCA Mod.
 Dirt Late Model
 Sprint
 Misc.
 Elbow Applications
 Mufflers
 Chassis Applications

Chevy Stock Clip Header



Right side front view

Right side top view

TUBE DIAMETER	COLLECTOR DIA./LENGTH	STANDARD CHEVY #	CRATE MOTOR #	PRICE
1 5/8"	3" x 8"	155	155CM2	269.95
1 5/8" - 1 3/4"	3 1/2" x 8"	155V	155VCM	329.95
1 5/8" - 1 3/4"	3" x 8"	155V-3	155VCM-3	329.95
1 3/4"	3 1/2" x 8"	156	156CM	269.95
1 3/4"	3" x 8"	156-3	-----	269.95
1 3/4" - 1 7/8"	3 1/2" x 9"	156V	156VCM	369.95
1 7/8"	3 1/2" x 9"	157	-----	459.95

Fits straight or angle plug heads.
 Spread port Available

Exits over frame rail. (Both sides)
 Bolts and Gaskets included

CM = 604 Crate Motor
 CM2 = 602 Crate Motor

TUBE DIAMETER	COLLECTOR DIA./LENGTH	STANDARD CHEVY #	PRICE	SPREAD PORT #	PRICE
1 5/8"	3" x 8"	125	289.95	----	----
1 5/8" - 1 3/4"	3 1/2" x 8"	125V	349.95	----	----
1 5/8" - 1 3/4"	3" x 8"	125V-3	349.95	----	----
1 3/4"	3 1/2" x 8"	126	289.95	----	----
1 3/4"	3" x 8"	126-3	289.95	----	----
1 3/4" - 1 7/8"	3 1/2" x 9"	126V	369.95	126VSP	449.95

Fits straight or angle plug heads.
 Exits over frame rail. (Both sides)
 Will not fit with stock upper control arms.
 Engine must be moved back.
 Bolts and Gaskets included
 Temporary non-high temperature paint



Mopar Available

Camaro Stock Clip

Fits 1977-1990 Caprice
 B - Body Style



Must use stock height springs.

CM = 604 Crate Motor
 CM2 = 602 Crate Motor

TUBE DIAMETER	COLL. DIA./LENGTH	STANDARD PORT #	CRATE MOTOR #	PRICE
1 5/8"	3" x 8"	103	103CM2	289.95
1 5/8" - 1 3/4"	3" x 8"	103V-3	103VCM-3	349.95
1 5/8" - 1 3/4"	3 1/2" x 8"	103V	103VCM	349.95
1 3/4"	3" x 8"	104-3	104CM-3	289.95
1 3/4"	3 1/2" x 8"	104	104CM	289.95
1 3/4" - 1 7/8"	3 1/2" x 9"	104V	104VCM	369.95
1 7/8"	3 1/2" x 9"	105	----	459.95

Metric Stock Clip (G-Body)

Fits 1964-1967 Malibu

TUBE DIAMETER	COLL. DIA./LENGTH	STANDARD CHEVY #	CRATE MOTOR #	PRICE
1 5/8"	3" x 8"	107	107CM2	289.95
1 5/8" - 1 3/4"	3" x 8"	107V-3	107VCM-3	349.95
1 5/8" - 1 3/4"	3 1/2" x 8"	107V	-----	349.95
1 3/4"	3" x 8"	108-3	108CM-3	289.95
1 3/4"	3 1/2" x 8"	108	108CM	289.95
1 3/4" - 1 7/8"	3 1/2" x 9"	108V	108VCM	369.95
1 7/8"	3 1/2" x 9"	109	-----	459.95
1 7/8" - 2"	3 1/2" x 9"	109V	-----	559.95



Must use stock height springs.

CM = 604 Crate Motor
 CM2 = 602 Crate Motor

Tractor/Derby
 Dirt Mod.
 4 Cyl. Drag
 Collectors
 180° Crossover
 Flanges/Gaskets
 Stock Clip
 Street Stock
 U & J Bends
 X & Y Pipes
 Turnouts & Extensions
 Misc.
 Elbow Applications
 Mufflers
 Chassis
 IMCA Mod.
 Dirt Late Model
 Sprint
 Midget
 Chassis Applications

479-474-7529
 Fax # 479-474-2249
 Van Buren, AR
 www.SchoenfeldHeaders.com



IMCA-USRA Hobby Stock

IMCA Legal - 1485-20 , 1485CM2-22
 USRA Legal - 1485-22 , 1485CM2-22

5/16" Flange, 16 ga. Primaries.
 -20=2" -22=2 1/4" 16 ga. Reducers included.
 Excellent spark plug access.

TUBE DIAMETER	COLLECTOR DIA./LENGTH	CHEVY	PRICE
1 5/8"	3" x 5"	1485-20	259.95
1 5/8"	3" x 5"	1485-22	259.95

TUBE DIAMETER	COLLECTOR DIA./LENGTH	CHEVY 602 CRATE	PRICE
1 5/8"	3" x 5"	1485CM2-22	259.95

Elbow



DIA.	ANGLE°	ELBOW	PRICE
2"	42°	2042L	17.95
2"	52°	2045R	17.95
2 1/4"	42°	2242L	17.95
2 1/4"	52°	2245R	17.95

Turnout



DIA.	LENGTH	TURNOUT	PRICE
2"	7 1/2"	2025	18.95
2 1/4"	7 1/2"	2225	18.95

For reducers see page 44, 3020,3022

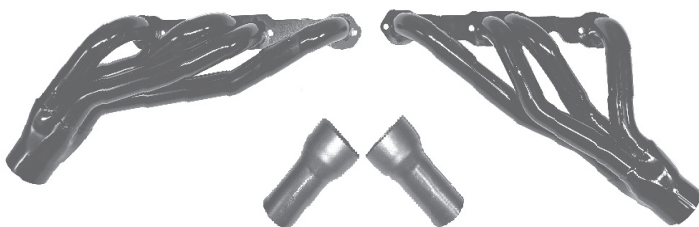

Chevy Stock Car IMCA - UMP

Exits inside frame rail

No clearance issues with oil filter, spark plugs,
 starter, kick out oil pan, rear mounts, valve covers.
 Clears firewall that is minimum 7" from back of block.



Fits Harris, Jet, Victory

TUBE DIAMETER	COLLECTOR DIA./LENGTH	STANDARD CHEVY #	CRATE MOTOR #	PRICE	SPREAD PORT & 18° CHEVY	PRICE
1 5/8"	3" x 8"	195	195CM2	269.95	-----	-----
1 5/8" - 1 3/4"	3" x 8"	195V-3	195VCM-3	329.95	-----	-----
1 3/4"	3" x 8"	196-3	196CM-3	269.95	-----	-----
1 3/4" - 1 7/8"	3 1/2" x 9"	196V	196VCM	369.95	196VSP - 196V18	449.95

Bolts and Gaskets included
 80 degree elbow available - part # 3081
 CM = 604 Crate Motor
 CM2 = 602 Crate Motor
 Exits outside frame rail



TUBE DIAMETER	COLLECTOR DIA./LENGTH	STANDARD CHEVY #	CRATE MOTOR #	PRICE
1 5/8"	3" x 8"	197	197CM2	269.95
1 5/8" - 1 3/4"	3" x 8"	197V-3	197VCM-3	329.95
1 3/4"	3" x 8"	198-3	198CM-3	269.95
1 3/4" - 1 7/8"	3 1/2" x 9"	198V	198VCM	369.95

Bolts and Gaskets included

Schoenfeld headers are not legal for sale or use on any pollution controlled vehicle intended for street or highway use.

Chassis Applications | Midget Sprint | Dirt Late Model | IMCA Mod. | Chassis | Street Stock | Stock Clip | 180° Crossover | Crossover | Tractor/Derby
 Mufflers | Elbow Applications | Misc. | Turnouts & Extensions | X & Y Pipes | U & J Bends | Flanges/Gaskets | Collectors | Drag 4 Cyl. | Dirt Mod.

Chevy Street Stock

1973 - 1988 Chevy Malibu, Monte Carlo, Pontiac Grand Prix, Olds Cutlass, Buick Regal.
 Also Camaro, 70 - 81

Can use solid side and rear mounts

WILL FIT straight or angle plug heads, fit with some mini starters, fit some kick-out oil pans, short oil filter.

WILL NOT FIT stock air-con box

TUBE DIAMETER	COLLECTOR DIA./LENGTH	STANDARD CHEVY #	CRATE MOTOR #	PRICE	SPREAD PORT #	CHEVY 18° #	PRICE
1 1/2"	2 1/2" x 8"	184	184CM2	219.95	----	----	----
1 1/2" - 1 5/8"	3" x 8"	184V	----	319.95	----	----	----
1 5/8"	3" x 8"	185	185CM2	219.95	----	----	----
1 5/8" - 1 3/4"	3" x 8"	185V	185VCM	279.95	----	----	----
1 3/4"	3 1/2" x 8"	186	186CM	219.95	----	----	----
1 3/4"	3" x 8"	186-3	186CM-3	249.95	----	----	----
1 3/4" - 1 7/8"	3 1/2" x 9"	186V	186VCM	369.95	186VSP	186V18	449.95
1 7/8"	3 1/2" x 9"	187	----	459.95	187SP	187-18	519.95



CM2 = 602 Crate Motor

Oil Filters Such As:

Wix 51069 - AC PF24

Designed to fit with engine in stock location.

CM = 604 Crate Motor

Ceramic Coating add \$350.00

Bolts and Gaskets included



1973 - 1988 Chevy Malibu, Monte Carlo,
 Pontiac Grand Prix, Olds Cutlass, Buick Regal.
 Also Camaro 70 - 81.

Clears side and rear engine mounts.

WILL FIT straight or angle plug heads.

WILL CLEAR stock manual clutch linkage ball.

WILL NOT FIT stock air-con box



Must use short oil filter.

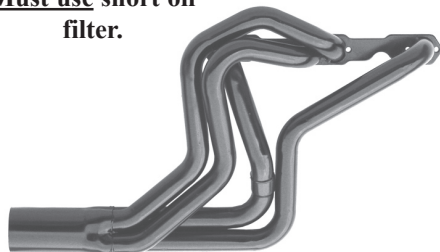

Spread port & 18° available for 1 3/4" & 1 7/8"

TUBE DIAMETER	COLLECTOR DIA./LENGTH	STANDARD CHEVY #	CRATE MOTOR #	PRICE
1 1/2" - 1 5/8"	3" x 8"	184VM	----	319.95
1 5/8"	3" x 8"	185M	185MCM2	229.95
1 5/8" - 1 3/4"	3" x 8"	185VM	185VMCM	289.95
1 3/4"	3 1/2" x 8"	186M	186MCM	229.95
1 3/4"	3" x 8"	186M-3	186MCM-3	259.95
1 3/4" - 1 7/8"	3 1/2" x 9"	186VM	186VMCM	369.95
1 7/8"	3 1/2" x 9"	187M	----	459.95

Designed to fit with engine in stock location.

CM = 604 Crate Motor

CM2 = 602 Crate Motor

Bolts and Gaskets included

479-474-7529
 Fax # 479-474-2249
 Van Buren, AR
 www.SchoenfeldHeaders.com



Street Stock

Camaro 70 - 81, Chevy II, Nova 75-79
Chevelle 64 - 77, Monte Carlo 72 - 77

TUBE DIAMETER	COLLECTOR DIA./LENGTH	STANDARD CHEVY #	PRICE
1 5/8"	3" x 8"	165	229.95
1 5/8" - 1 3/4"	3" x 8"	165V	289.95
1 3/4"	3 1/2" x 8"	166	229.95
1 3/4"	3" x 8"	166-3	249.95

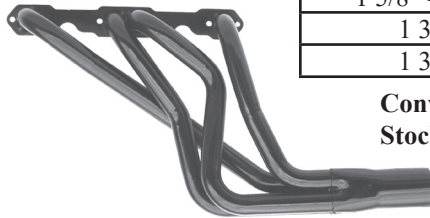

Conventional Style Headers for Car with Engines in Stock Location or engine set back.

WILL NOT fit angle plug heads.
WILL NOT clear rear mounts.

Camaro 70-81, Monte Carlo 72-77, Nova 75-79
 Will Not Fit Chevelle.

TUBE DIAMETER	COLLECTOR DIA./LENGTH	STANDARD CHEVY #	CRATE MOTOR #	PRICE	SPREAD PORT #	PRICE
1 5/8"	3" x 8"	165A	165ACM2	229.95	----	----
1 5/8" - 1 3/4"	3" x 8"	165VA	165VACM	289.95	----	----
1 3/4"	3 1/2" x 8"	166A	166ACM	229.95	----	----
1 3/4"	3" x 8"	166A-3	166ACM-3	249.95	----	----
1 3/4" - 1 7/8"	3 1/2" x 9"	166VA	166VACM	369.95	166VASP	449.95
1 7/8"	3 1/2" x 9"	167A	----	459.95	167ASP	519.95

FITS Straight or angle plug heads, solid side and rear mounts, stock clutch linkage.

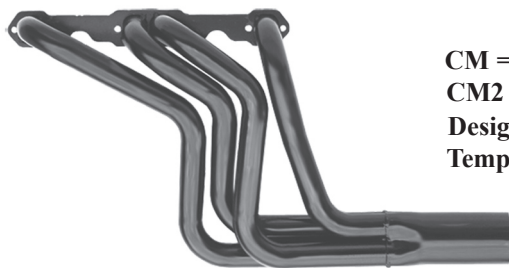

CM = 604 Crate Motor
 CM2 = 602 Crate Motor
 Designed to fit with engine in stock location
 Temporary non-high temperature paint

Ford Street Stock / Truck

Designed to fit Camaro, Intermediate GM, Front Clips.

TUBE DIAMETER	COLLECTOR DIA./LENGTH	WINDSOR 289-302-351	CRATE MOTOR	DART/ "N" SPORTSMAN	PRICE
1 5/8"	3" x 8"	385	385CM	*385N	329.95
1 5/8" - 1 3/4"	3" x 8"	385V	385VCM	*385VN	389.95
1 3/4"	3 1/2" x 8"	386	386CM	*386N	329.95

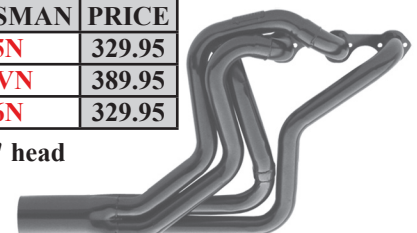
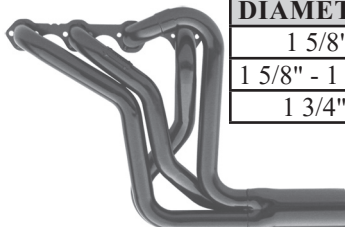

*Fits the wide Dart Bolt Pattern and Sportsman "N" head
 (Available for Edelbrock)
 Fits Ford Trucks 1967-1972

Chassis Applications | Midget | Sprint | Dirt Late Model | IMCA Mod. | Chassis | Street Stock | Stock Clip | 180° Crossover | Crossover | Tractor/Derby | Mufflers | Elbow Applications | Misc. | Turnouts & Extensions | X & Y Pipes | U & J Bends | Flanges/Gaskets | Collectors | Drag 4 Cyl. | Dirt Mod.

Chevy Drag "Street Class"

Camaro/Nova 1967-1969

TUBE DIAMETER	COLLECTOR DIA./LENGTH	STANDARD CHEVY #	PRICE
1 5/8" - 1 3/4"	3" x 8"	115V-3	499.95
1 3/4"	3 1/2" x 8"	116	439.95
1 3/4"	3" x 8"	116-3	439.95
1 3/4" x 1 7/8"	3 1/2" x 9"	116V	499.95

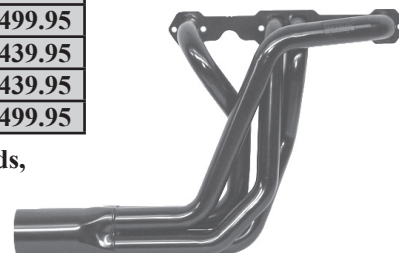
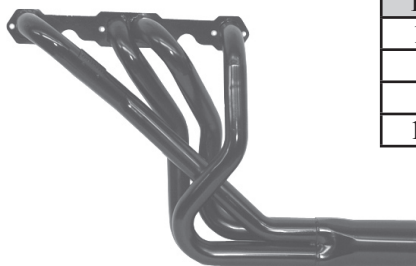

Fits Motor in stock location, straight plug heads, stock clutch linkage.

2300cc Ford Pinto Tri - Y Headers

TUBE DIAMETER	COLLECTOR DIAMETER	2300CC #	PRICE
1 1/2" - 1 5/8"	3"	F232VY	439.95
1 5/8" - 1 3/4"	3"	F233VY	439.95

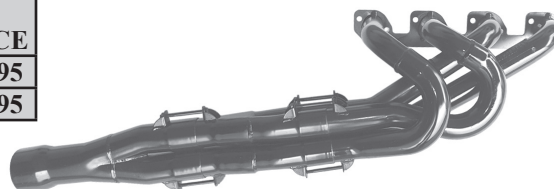

Bolts and Gaskets included
 Temporary non-high temperature paint

2000cc & 2300cc Ford Pinto Headers

"Pro Four" Tube Chassis Style or goes through Firewall on production Pinto or Mustang.

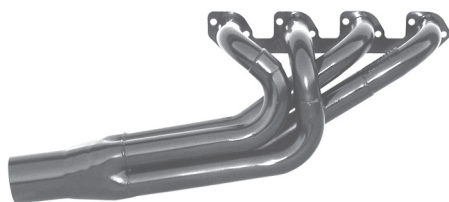

TUBE DIAMETER	COLLECTOR DIA./LENGTH	2300CC #	PRICE	2000CC #	PRICE
1 1/2" - 1 5/8"	3" x 8"	F234V	179.95	F204V	209.95
1 5/8" - 1 3/4"	3" x 8"	F235V	179.95	F205V	209.95
GASKETS	----	FG23	13.95	FG20	13.95

Bolts and Gaskets included
 Temporary non-high temperature paint

Production Chassis type:
 (exits under car on production Pinto or Mustang)
 Will not clear 2.0 stock motor mounts.

TUBE DIAMETER	COLLECTOR DIA./LENGTH	2300CC #	PRICE	2000CC #	PRICE
1 1/2" - 1 5/8"	3" x 8"	F238V	189.95	F208V	209.95
1 5/8" - 1 3/4"	3" x 8"	F239V	189.95	F209V	209.95
GASKETS	----	FG23	13.95	FG20	13.95



Bolts and Gaskets included
 Temporary non-high temperature paint

Also fits Ford Ranger 1983-1992



Chevy Modified

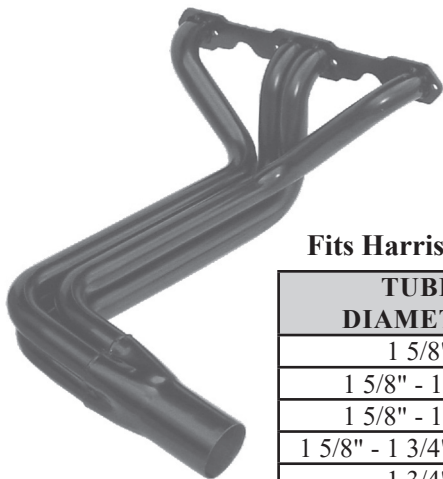

Fits Harris, Skyrocket, Victory.

TUBE DIAMETER	COLLECTOR DIA./LENGTH	STANDARD CHEVY #	CRATE MOTOR #	PRICE
1 5/8"	3" x 8"	11619H	11619HCM2	289.95
1 5/8" - 1 3/4"	3 1/2" x 8"	1161V9H	1161V9HCM	349.95
1 5/8" - 1 3/4"	3" x 8"	1161V9H-3	1161V9HCM-3	349.95
1 5/8" - 1 3/4" - 1 7/8"	3" x 9"	1161V39H-3	1161V39HCM-3	409.95
1 3/4"	3 1/2" x 8"	11629H	11629HCM	289.95
1 3/4" - 1 7/8"	3 1/2" x 8"	1162V9H	1162V9HCM	349.95

Bolts and Gaskets included
 CM = 604 Crate Motor
 CM2 = 602 Crate Motor

Modified Mid-Length Primary Design

Chevy

Fits BMS, Dirtworks, GRT, Harris, Hoffman, Jet Racing, Larry Shaw, Xtreme (Pierce uses 1106A style)

TUBE DIAMETER	COLLECTOR DIA./LENGTH	STANDARD CHEVY #	CRATE MOTOR #	PRICE	SPREAD PORT/D.N #	CHEVY 18° #	PRICE
1 5/8"	3" x 8"	1105	1105CM2	289.95	----	----	----
1 5/8" - 1 3/4"	3 1/2" x 8"	1105V	1105VCM	349.95	----	----	----
1 5/8" - 1 3/4"	3" x 8"	1105V-3	1105VCM-3	349.95	----	----	----
1 3/4"	3 1/2" x 8"	1106	1106CM	289.95	1106SP	----	359.95
1 3/4" - 1 7/8"	3 1/2" x 9"	1106V	1106VCM	349.95	1106VSP	1106V18	409.95

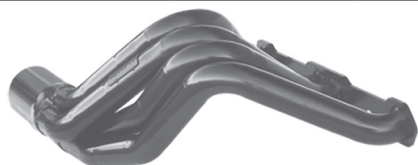

CM = 604 Crate Motor
 CM2 = 602 Crate Motor
 Smoother Power Band



Ford

Fits BMS, Dirtworks, GRT, Harris, Hoffman, Jet Racing, Larry Shaw.

TUBE DIAMETER	COLLECTOR DIA./LENGTH	WINDSOR 289-302-351 #	DART "N" #	PRICE
1 5/8"	3" x 8"	3105	3105N	369.95
1 5/8" - 1 3/4"	3 1/2" x 8"	3105V	3105VN	439.95
1 5/8" - 1 3/4"	3" x 8"	3105V-3	3105VN-3	439.95
1 3/4"	3 1/2" x 8"	3106	3106N	369.95
1 3/4" - 1 7/8"	3 1/2" x 9"	3106V	3106VN	439.95

Modified Long-Tube Design

Fits BMS, Dirtworks, Hoffman, Hot, Jet, KMOD, Bob Pierce, Pro, Quick, Sardeson, Smiley's, Swartz, Victory.

TUBE DIAMETER	COLLECTOR DIA./LENGTH	STANDARD CHEVY #	CRATE MOTOR #	PRICE	SPREAD PORT #	CHEVY 18° #	PRICE
1 5/8"	3" x 8"	1185	1185CM2	289.95	----	----	----
1 5/8" - 1 3/4"	3 1/2" x 8"	1185V	1185VCM	349.95	----	----	----
1 5/8" - 1 3/4"	3" x 8"	1185V-3	1185VCM-3	349.95	----	----	----
1 5/8" - 1 3/4" - 1 7/8"	3" x 9"	1185V3-3	1185V3CM-3	409.95	----	----	----
1 3/4"	3 1/2" x 8"	1186	1186CM	289.95	1186SP	----	349.95
1 3/4" - 1 7/8"	3 1/2" x 9"	1186V	1186VCM	349.95	1186VSP	1186V18	409.95

Available in LS1-LS7
 Ceramic Coating, Add \$350.00
 Bolts and Gaskets included
 CM = 604 Crate Motor
 CM2 = 602 Crate Motor
 Temporary non-high temperature paint

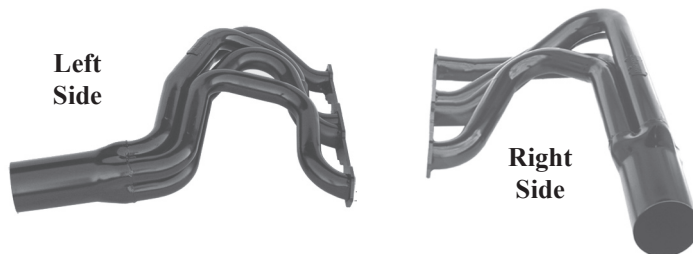

Fits BMS, Bob Pierce, Dirtworks, Harris, Hoffman, Hot, Hughes, Jet, Larry Shaw, Lightning, Lou Fegers, M&M, Pro, Sardeson.

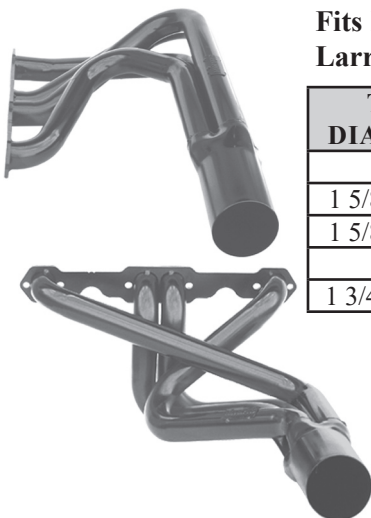

TUBE DIAMETER	COLLECTOR DIA./LENGTH	STANDARD CHEVY #	PRICE	SPREAD PORT #	CRATE MOTOR #	PRICE
1 5/8"	3" x 8"	1175	289.95	----	1175CM2	289.95
1 5/8" - 1 3/4"	3 1/2" x 8"	1175V	349.95	----	1175VCM	349.95
1 5/8" - 1 3/4"	3" x 8"	1175V-3	349.95	----	1175VCM-3	349.95
1 3/4"	3 1/2" x 8"	1176	289.95	----	----	----
1 3/4" - 1 7/8"	3 1/2" x 9"	1176V	349.95	1176VSP	----	409.95

Ceramic Coating, Add \$350.00
 Chevy 18° Available
 Bolts and Gaskets included
 CM = 604 Crate Motor
 CM2 = 602 Crate Motor
 Temporary non-high temperature paint

Small Block Chevy



Fits most chassis

TUBE DIAMETER	COLLECTOR DIA./LENGTH	STANDARD CHEVY #	PRICE
1 3/4"	3 1/2" x 8"	172	279.95
1 7/8"	3 1/2" x 9"	173	329.95

Bolts and Gaskets included

Tractor/Derby
 4 Cyl. Drag
 Collector
 180° Crossover
 Flanges/Gaskets
 Stock Clip
 Street Stock
 U & J Bends
 Chassis
 X & Y Pipes
 Turnouts & Extensions
 Misc.
 Elbow Applications
 Mufflers
 Dirt Mod.
 Crossover
 180° Crossover
 Flanges/Gaskets
 Stock Clip
 Street Stock
 U & J Bends
 Chassis
 IMCA Mod.
 Dirt Late Model
 Sprint
 Midget
 Chassis Applications
 Mufflers



Modified Long-Tube Design

Fits Most Chassis (See Chassis Application Chart On Page 39)

TUBE DIAMETER	COLLECTOR DIA./LENGTH	STANDARD CHEVY #	CRATE MOTOR #	PRICE	SPREAD PORT	18° CHEVY	PRICE
1 1/2" - 1 3/4" - 1 7/8"	3" x 9"	----	1154LBV23CM-3	429.95	----	----	----
1 5/8"	3" x 8"	1155LB	1155LBCM2	289.95	----	----	----
1 5/8" - 1 3/4"	3" x 8"	1155LBV-3	1155LBVCM-3	349.95	----	----	----
1 5/8" - 1 3/4" - 1 7/8"	3" x 9"	1155LBV3-3	1155LBV3CM-3	409.95	----	----	----
1 3/4"	3 1/2" x 8"	1156LB	1156LBCM	289.95	----	----	----
1 3/4" - 1 7/8"	3 1/2" x 9"	1156LBV	1156LBVCM	349.95	1156LBVSP	1156LBV18	409.95



Bolts and Gaskets included
 CM = 604 Crate Motor
 CM2 = 602 Crate Motor



Fits Assault, Beakbuilt, Chubby, Sidebitter, Taylor, Victory

TUBE DIAMETER	COLLECTOR DIA./LENGTH	STANDARD CHEVY #	CRATE MOTOR #	PRICE	SPREAD PORT	18° CHEVY	PRICE
1 1/2" - 1 3/4" - 1 7/8"	3" x 9"	----	1154LV23CM-3	429.95	----	----	----
1 5/8"	3" x 8"	1155L	1155LCM2	289.95	----	----	----
1 5/8" - 1 3/4"	3" x 8"	1155LV-3	1155LVCM-3	349.95	----	----	----
1 5/8" - 1 3/4" - 1 7/8"	3" x 9"	1155LV3-3	1155LV3CM-3	409.95	----	----	----
1 3/4"	3 1/2" x 8"	1156L	1156LCM	289.95	----	----	----
1 3/4" - 1 7/8"	3 1/2" x 9"	1156LV	1156LVCM	349.95	1156LVSP	1156LV18	409.95

Fits LG2, MB Customs

TUBE DIAMETER	COLLECTOR DIA./LENGTH	STANDARD CHEVY #	CRATE MOTOR #	PRICE	18° CHEVY	PRICE
1 1/2" - 1 3/4" - 1 7/8"	3" x 9"	----	1154LBV23FWCM-3	429.95	----	----
1 5/8"	3" x 8"	1155LBFW	1155LBFWCM2	289.95	----	----
1 5/8" - 1 3/4"	3" x 8"	1155LBVFW-3	1155LBVFWCM-3	349.95	----	----
1 5/8" - 1 3/4" - 1 7/8"	3" x 9"	1155LBV3FW-3	1155LBV3FWCM-3	409.95	----	----
1 3/4"	3 1/2" x 8"	1156LBFW	1156LBFWCM	289.95	----	----
1 3/4" - 1 7/8"	3 1/2" x 9"	1156LBVFW	1156LBVFWCM	349.95	1156LBVFW18	409.95



W = 1 1/2" Up Right Side
 F = 1" Farther Out Right Side
 G = 2" Farther Out Right Side

Bolts and Gaskets included
 CM = 604 Crate Motor
 CM2 = 602 Crate Motor



W = 1 1/2" Up Right Side

Chassis Applications | Midget Sprint | Dirt Late Model | IMCA Mod. | Chassis | Street Stock | Stock Clip | 180° Crossover | Crossover | Tractor/Derby
 Mufflers | Elbow Applications | Misc. | Turnouts & Extensions | X & Y Pipes | U & J Bends | Flanges/Gaskets | Drag | 4 Cyl. | Dirt Mod.

Modified Long-Tube Design

Longer primaries for maximum torque and horsepower

Fits Harris, Hoffman, MB Custom Razor, Sidebitter chassis

TUBE DIAMETER	COLLECTOR DIA./LENGTH	STANDARD CHEVY #	CRATE MOTOR #	PRICE	SPREAD PORT	18° CHEVY	PRICE
1 5/8"	3" x 8"	1101	1101CM2	289.95	----	----	----
1 5/8" - 1 3/4"	3" x 8"	1101V-3	1101VCM-3	349.95	----	----	----
1 5/8" - 1 3/4" - 1 7/8"	3" x 8"	1101V3-3	1101V3CM-3	409.95	----	----	----
1 3/4"	3 1/2" x 8"	1102	1102CM	289.95	----	----	----
1 3/4"	3" x 8"	1102-3	1102CM-3	289.95	----	----	----
1 3/4" - 1 7/8"	3 1/2" x 9"	1102V	1102VCM	349.95	1102VSP	1102V18	409.95



Bolts and Gaskets included
 CM = 604 Crate Motor
 CM2 = 602 Crate Motor
 Temporary non-high temperature paint



Modified Headers

Longer primaries for maximum torque and horsepower

Fits Rage, *H- Harris chassis (2016 and up)- *W- Elite, Longhorn, Razor

TUBE DIAMETER	COLLECTOR DIA./LENGTH	STANDARD CHEVY #	CRATE MOTOR #	PRICE	SPREAD PORT	18° CHEVY	PRICE
1 1/2" - 1 3/4" - 1 7/8"	3" x 9"	----	1130V23CM-3	429.95	----	----	----
1 5/8"	3" x 8"	1131	1131CM2	289.95	----	----	----
1 5/8" - 1 3/4"	3" x 8"	1131V-3	1131VCM-3	349.95	----	----	----
1 5/8" - 1 3/4" - 1 7/8"	3" x 9"	1131V3-3	1131V3CM-3	409.95	----	----	----
1 3/4" - 1 7/8"	3 1/2" x 9"	1132V	----	349.95	1132VSP	1132V18	409.95

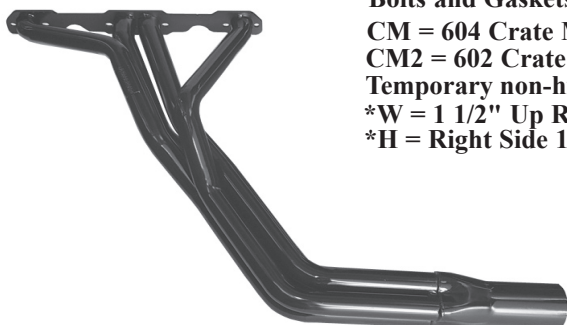

Bolts and Gaskets included
 CM = 604 Crate Motor
 CM2 = 602 Crate Motor
 Temporary non-high temperature paint
 *W = 1 1/2" Up Right Side
 *H = Right Side 1101B



W = 1 1/2" Up Right Side



Adjustable Modified Headers Small Block Chevy

TUBE DIAMETER	COLLECTOR DIA./LENGTH	FLANGE	L-STYLE 3 R-STYLE 8	L-STYLE 6 R-STYLE 8	L-STYLE 9 R-STYLE 8	L-STYLE 9H R-STYLE 8	PRICE
1 1/2" - 1 5/8"	3" x 8"	STANDARD	160-38	160-68	160-98	160-98H	259.95
1 5/8" - 1 3/4"	3" x 8"	STANDARD	161-38	161-68	161-98	161-98H	259.95
1 3/4" - 1 7/8"	3 1/2" x 9"	STANDARD	162-38	162-68	162-98	162-98H	349.95
1 3/4" - 1 7/8"	3 1/2" x 9"	SPRD PORT	162-38SP	162-68SP	162-98SP	162-98HSP	409.95
1 3/4" 1 7/8"	3 1/2" x 9"	18° CHEVY	162-38-18	162-68-18	162-98-18	162-98H-18	409.95
1 7/8" - 2"	3 1/2" x 9"	STANDARD	163-38	163-68	163-98	163-98H	399.95

Bolts and Gaskets included

Small Block Ford

TUBE DIAMETER	COLLECTOR DIA./LENGTH	FLANGE	L-STYLE 3 R-STYLE 8	L-STYLE 6 R-STYLE 8	L-STYLE 9 R-STYLE 8	L-STYLE 9H R-STYLE 8	PRICE
1 5/8" - 1 3/4"	3" x 8"	WINDSOR	361-38	361-68	361-98	361-98H	369.95
1 3/4" - 1 7/8"	3 1/2" x 9"	WINDSOR	362-38	362-68	362-98	362-98H	389.95
1 5/8" - 1 3/4"	3" x 8"	*DART/"N"	*361-38N	*361-68N	*361-98N	*361-98HN	369.95
1 3/4" - 1 7/8"	3 1/2" x 9"	*DART/"N"	*362-38N	*362-68N	*362-98N	*362-98HN	389.95
1 3/4" - 1 7/8"	3 1/2" x 9"	CLEVELAND	562-38	562-68	562-98	562-98H	409.95
1 3/4" - 1 7/8"	3 1/2" x 9"	SVO (ALUM.)	662-38	662-68	662-98	662-98H	409.95

Specify for 4 barrel Cleveland Flange

*Fits the wide Dart bolt pattern and Sportsman "N" head

Available for Edelbrock

Small Block Chevy

TUBE DIAMETER	COLLECTOR DIA./LENGTH	STANDARD CHEVY #	*CRATE MOTOR #	PRICE	SPREAD PORT #	CHEVY 18° #	PRICE
1 1/2"	3" x 8"	160	----	239.95	----	----	----
1 5/8"	3" x 8"	161	161CM2	189.95	----	----	----
1 5/8" - 1 3/4"	3" x 8"	161V-3	161VCM-3	259.95	----	----	----
1 3/4"	3 1/2" x 8"	162	162CM	199.95	----	----	----
1 7/8"	3 1/2" x 9"	163	----	339.95	163SP	163-18	399.95

Ceramic Coating add \$350.00

Bolts and Gaskets included

CM = 604 Crate Motor

CM2 = 602 Crate Motor



Small Block Ford

Bolts and Gaskets included

TUBE DIAMETER	COLLECTOR DIA./LENGTH	WINDSOR #	DART/"N" SPORTSMAN #	PRICE
1 5/8"	3" x 8"	361	361N	229.95
1 3/4"	3 1/2" x 8"	362	362N	269.95

(Available for Edelbrock)

TUBE DIAMETER	COLLECTOR DIA./LENGTH	CLEVELAND 2 BARREL #	CLEVELAND 4 BARREL #	PRICE
1 3/4"	3 1/2" x 8"	562	----	309.95
1 3/4"	3 1/2" x 8"	----	562-4B	339.95

Gaskets not included or available for Cleveland



Chassis Applications | Midget Sprint | Dirt Late Model | IMCA Mod. | Chassis | Street Stock | Stock Clip | 180° Crossover | Crossover | Tractor/Derby
 Mufflers | Elbow Applications | Misc. | Turnouts & Extensions | X & Y Pipes | U & J Bends | Flanges/Gaskets | Collectors | Drag 4 Cyl. | Dirt Mod.

Ford Modified Long-Tube Design

Longer primaries for maximum torque and horsepower

Fits Dirtworks and most other Chassis

TUBE DIAMETER	COLLECTOR DIA./LENGTH	WINDSOR #	DART/ "N" HEAD #	PRICE
1 5/8" - 1 3/4"	3 1/2" x 8"	3185V	*3185VN	439.95
1 5/8" - 1 3/4"	3" x 8"	3185V-3	*3185VN-3	439.95
1 3/4"	3 1/2" x 8"	3186	*3186N	369.95
1 3/4" - 1 7/8"	3 1/2" x 9"	3186V	*3186VN	439.95

*Fits wide Dart bolt pattern and "N" head
 Ceramic Coating, Add \$350.00
 Bolts and Gaskets included

Left Side

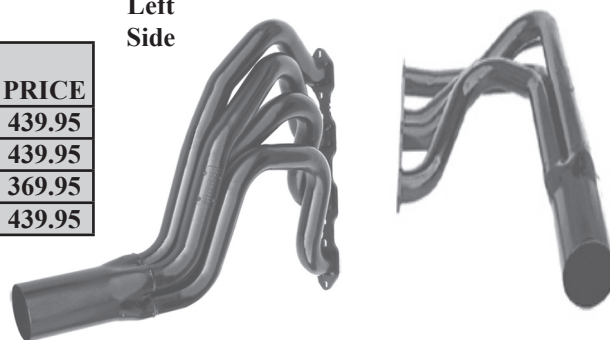

Chevy Modified Short Tube Design

Fits BMS, Hughes, Larry Shaw, Razor, TRE, Xtreme



TUBE DIAMETER	COLLECTOR DIA./LENGTH	STANDARD CHEVY #	CRATE MOTOR #	PRICE
1 5/8"	3" x 8"	1145	1145CM2	289.95
1 5/8" - 1 3/4"	3 1/2" x 8"	1145V	1145VCM	349.95
1 5/8" - 1 3/4"	3" x 8"	1145V-3	1145VCM-3	349.95
1 3/4"	3 1/2" x 8"	1146	1146CM	289.95
1 3/4" - 1 7/8"	3 1/2" x 9"	1146V	1146VCM	349.95



Available right side mirror image of left side

Bolts and Gaskets included
 Available Spread Port and 18"
 CM = 604 Crate Motor
 CM2 = 602 Crate Motor
 Temporary non-high temperature paint

Modified Long Tube Design

Fits Hughes, J Car, Kraft, Rage, TRE

TUBE DIAMETER	COLLECTOR DIA./LENGTH	STANDARD CHEVY #	CRATE MOTOR #	PRICE	SPREAD PORT	PRICE
1 5/8"	3" x 8"	1165	1165CM2	329.95	----	----
1 5/8" - 1 3/4"	3 1/2" x 8"	1165V	1165VCM	389.95	----	----
1 5/8" - 1 3/4"	3" x 8"	1165V-3	1165VCM-3	389.95	----	----
1 3/4"	3 1/2" x 8"	1166	1166CM	329.95	----	----
1 3/4" - 1 7/8"	3 1/2" x 9"	1166V	1166VCM	389.95	1166VSP	449.95

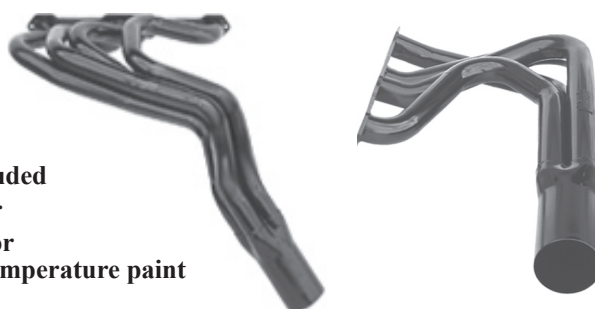

Bolts and Gaskets included
 CM = 604 Crate Motor
 CM2 = 602 Crate Motor
 Temporary non-high temperature paint



SB Chevy Modified Tri-Y

Big Bend Die - 4" Radius Bends

Fits Brucebilt, GRT, Impressive, IROC, Mark Bush, Rocket by Ruhlman, Shaw

TUBE DIAMETER	COLLECTOR DIA.	STANDARD CHEVY #	PRICE
1 5/8" - 1 3/4" - 1 7/8"	3 1/2"	1151LV3YZ	869.95
1 3/4" - 1 7/8"	3 1/2"	1152LVYZ	809.95
1 3/4" - 1 7/8" - 2"	3 1/2"	1152LV3YZ	869.95

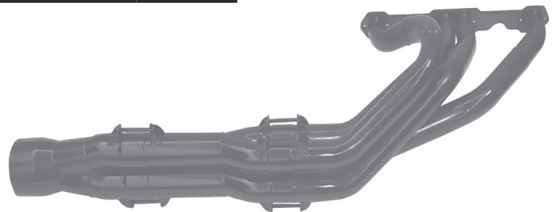
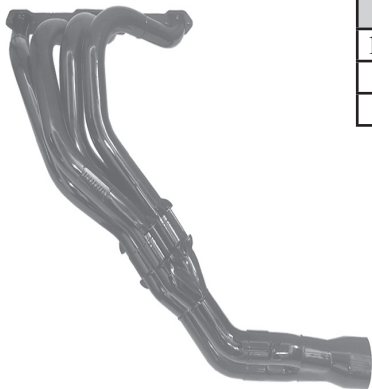

1152LV3YZ-BI Fits Billsbuilt
1152LV3YZ-IM Fits Impressive
1152LV3YZ-LT Fits Lightning
1152LV3YZ-MB Fits MB Customs
1152LV3YZ-SW Fits Shaw
1152LV3YZ-VB Fits Vanderbilt

Fits Beaksbuilt, LG2

TUBE DIAMETER	COLLECTOR DIA.	STANDARD CHEVY #	18° CHEVY #	PRICE
1 3/4" - 1 7/8"	3 1/2"	1142LVYZ	----	809.95
1 3/4" - 1 7/8"	3 1/2"	----	1142LVYZ18	869.95
1 3/4" - 1 7/8" - 2"	3 1/2"	1142LV3YZ	----	869.95
1 3/4" - 1 7/8" - 2"	3 1/2"	----	1142LV3YZ18	929.95

1142LVYZ-E Fits Elite
1142LVYZ-LE Fits Lethal

Spread Port & 18° Available for 1 3/4"

SB Chevy Modified Tri-Y

Fits Harris, Rage, Razor

TUBE DIAMETER	COLLECTOR DIA.	STANDARD CHEVY #	PRICE
1 3/4" - 1 7/8"	3 1/2"	1132LVY	809.95
1 3/4" - 1 7/8" - 2"	3 1/2"	1132LV3Y	869.95



1132LVY-DS - Fits Diamond Select
1132LVY-LH - Fits Longhorn

Spread Port & 18° Available for 1 3/4"

Chassis Applications | Midget | Sprint | Dirt Late Model | IMCA Mod. | Chassis | Street Stock | Stock Clip | 180° Crossover | Crossover | Tractor/Derby
 Mufflers | Elbow Applications | Misc. | Turnouts & Extensions | X & Y Pipes | U & J Bends | Flanges/Gaskets | Drag 4 Cyl. | Dirt Mod.

Long Primary Dirt Late Model Tri-Y Inside Frame Right Side

4 Into 2 Into 1 Tube
 Configuration for
 Increased Torque

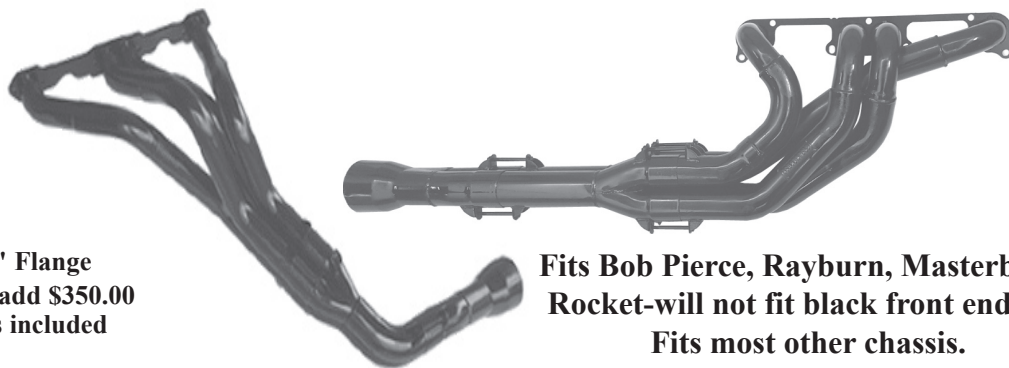

Comes With 5/16" Flange
 Ceramic Coating add \$350.00
 Bolts and Gaskets included

Fits Bob Pierce, Rayburn, Masterbilt,
 Rocket-will not fit black front end.
 Fits most other chassis.

Available Brodix Spec. Head

TUBE DIAMETER	COLL. DIA.	STANDARD CHEVY #	PRICE	SPREAD PORT #	13°, 15°, 16° CHEVY 18° #	PRICE
1 5/8" - 1 3/4"	3"	14160LVYIF	809.95	----	----	----
1 5/8" - 1 3/4" - 1 7/8"	3 1/2"	14160LV3YIF	869.95	----	----	----
1 3/4" - 1 7/8"	3 1/2"	14260LVYIF	809.95	14260LVYIFSP	14260LVYIF18	869.95
1 3/4" - 1 7/8" - 2"	3 1/2"	14260LV3YIF	869.95	14260LV3YIFSP	14260LV3YIF18	929.95
1 7/8" - 2"	3 1/2"	14360LVYIF	819.95	14360LVYIFSP	14360LVYIF18	879.95

Available Crate Motor

4 Into 2 Into 1 Tube
 Configuration for
 Increased Torque

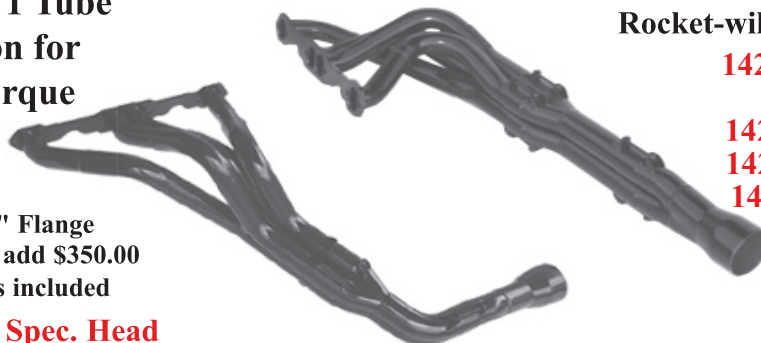

Comes With 5/16" Flange
 Ceramic Coating add \$350.00
 Bolts and Gaskets included

Fits Bob Pierce, Rayburn, Masterbilt,
 Rocket-will not fit black front end.

14260BLVY - Bloomquist
 2020 and newer
 14260LVY-CP- Capital
 14260LVY-LH2- Longhorn
 14260LVY-MB- MB Custom

Available Brodix Spec. Head

TUBE DIAMETER	COLL. DIA.	STANDARD CHEVY #	PRICE	SPREAD PORT #	13°, 15°, 16° CHEVY 18° #	PRICE	SB2 CHEVY #	PRICE
1 5/8" - 1 3/4"	3"	14160LVY	809.95	----	----	----	----	----
1 5/8" - 1 3/4" - 1 7/8"	3 1/2"	14160LV3Y	869.95	----	----	----	----	----
1 3/4" - 1 7/8"	3 1/2"	14260LVY	809.95	14260LVYSP	14260LVY18	869.95	14260LVYSB2	919.95
1 3/4" - 1 7/8" - 2"	3 1/2"	14260LV3Y	869.95	14260LV3YSP	14260LV3Y18	929.95	14260LV3YSB2	979.95
1 7/8" - 2"	3 1/2"	14360LVY	819.95	14360LVYSP	14360LVY18	879.95	14360LVYSB2	929.95

Available Crate Motor

4-7 Cam Swap

TUBE DIAMETER	COLL. DIA.	STANDARD CHEVY #	PRICE	SPREAD PORT #	13°, 15°, 16° CHEVY 18° #	PRICE	SB2 CHEVY #	PRICE
1 5/8" - 1 3/4"	3"	14167LVY	809.95	----	----	----	----	----
1 5/8" - 1 3/4" - 1 7/8"	3 1/2"	14167LV3Y	869.95	----	----	----	----	----
1 3/4" - 1 7/8"	3 1/2"	14267LVY	809.95	14267LVYSP	14267LVY18	869.95	14267LVYSB2	919.95
1 3/4" - 1 7/8" - 2"	3 1/2"	14267LV3Y	869.95	14267LV3YSP	14267LV3Y18	929.95	14267LV3YSB2	979.95
1 7/8" - 2"	3 1/2"	14367LVY	819.95	14367LVYSP	14367LVY18	879.95	14367LVYSB2	929.95

Available Crate Motor

Tractor/Derby
 Dirt Mod.
 4 Cyl.
 Drag
 Collectors
 Flanges/Gaskets
 U & J Bends
 X & Y Pipes
 Turnouts & Extensions
 Misc.
 Elbow Applications
 Mufflers
 180° Crossover
 Stock Clip
 Street Stock
 Chassis
 IMCA Mod.
 Dirt Late Model
 Sprint
 Midget
 Chassis Applications

479-474-7529
 Fax # 479-474-2249
 Van Buren, AR
www.SchoenfeldHeaders.com



Dirt Late Model Long Tube

24" - Rocket, 2012 Older Barry Wright, 2019-2020 TNT
 26" - GRT, Bob Pierce, Barry Wright,
 Bernheisel, Larry Shaw, Longhorn,
 Mastersbuilt, 2017 Rocket XR1,
 Rayburn and Warrior.



I/S - From head surface to inside left collector

CM = 604 Crate Motor

CM2 = 602 Crate Motor

@ = Spread Port

TUBE DIAMETER	COLLECTOR DIA./LENGTH	CRATE MOTOR # 24" TO I/S COLL.	CRATE MOTOR # 26" TO I/S COLL.	CRATE MOTOR # 28" TO I/S COLL.	PRICE
1 5/8"	3" x 8"	181-406LGCM2	181-606LGCM2	181-806LGCM2	329.95
1 5/8" - 1 3/4"	3 1/2" x 8"	181-406LVGCM2	181-606LVGCM2	181-806LVGCM2	389.95
1 5/8" - 1 3/4"	3" x 8"	181-406LVGCM2-3	181-606LVGCM2-3	181-806LVGCM2-3	389.95
1 5/8" - 1 3/4" - 1 7/8"	3" x 8"	181-406LV3GCM-3	181-606LV3GCM-3	181-806LV3GCM-3	449.95
1 3/4" - 1 7/8"	3 1/2" x 9"	182-406LVGCM	182-606LVGCM	182-806LVGCM	389.95
1 3/4" - 1 7/8"	3" x 8"	182-406LVGCM-3	182-606LVGCM-3	182-806LVGCM-3	389.95

TUBE DIAMETER	COLLECTOR DIA./LENGTH	STANDARD CHEVY # 24" TO I/S COLL.	STANDARD CHEVY # 26" TO I/S COLL.	STANDARD CHEVY # 28" TO I/S COLL.	PRICE
1 5/8" - 1 3/4"	3 1/2" x 8"	181-406LVG	181-606LVG	181-806LVG	389.95
1 5/8" - 1 3/4"	3" x 8"	181-406LVG-3	181-606LVG-3	181-806LVG-3	389.95
1 5/8" - 1 3/4" - 1 7/8"	3" x 8"	181-406LV3G-3	181-606LV3G-3	181-806LV3G-3	449.95
1 3/4" - 1 7/8"	3 1/2" x 9"	182-406LVG	182-606LVG	182-806LVG	389.95
1 3/4" - 1 7/8"	3 1/2" x 9"	@182-406LVGSP	@182-606LVGSP	@182-806LVGSP	449.95
1 3/4" - 1 7/8"	3" x 8"	182-406LVG-3	182-606LVG-3	182-806LVG-3	389.95
1 3/4" - 1 7/8"	3" x 8"	@182-406LVGSP-3	@182-606LVGSP-3	@182-806LVGSP-3	449.95

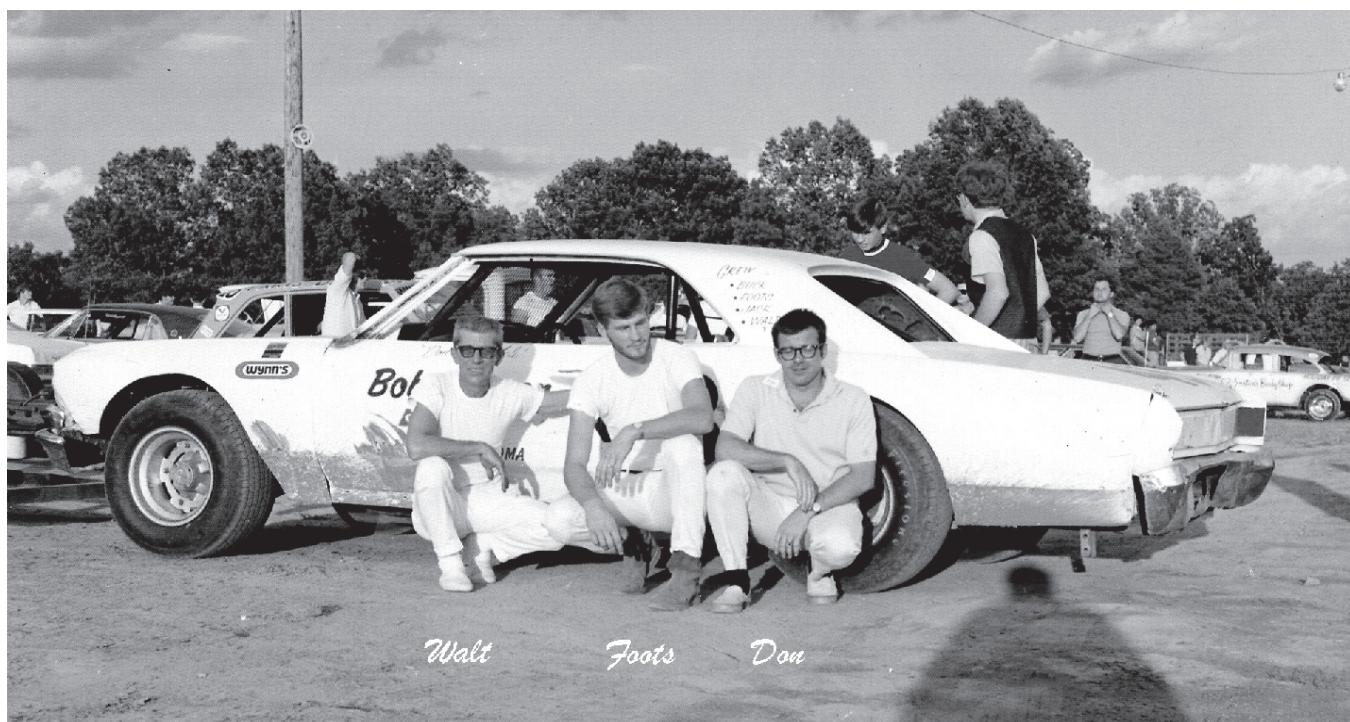

Walt Foots Don

Chassis Applications | Midget | Sprint | Dirt Late Model | IMCA Mod. | Chassis | Street Stock | Stock Clip | 180° Crossover | Crossover | Tractor/Derby | Mufflers | Elbow Applications | Misc. | Turnouts & Extensions | X & Y Pipes | U & J Bends | Flanges/Gaskets | Collectors | Drag | 4 Cyl. | Dirt Mod.

Chevy Dirt Late Model

Fits GRT, Stinger, TNT, Bob Pierce, Barry Wright, Bullitt, Larry Shaw, Raider, Warrior and Rayburn



Left Side

CM = 604 Crate Motor
 Temporary non-high temperature paint

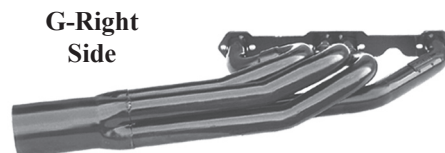

G-Right Side

605 OFF-SET

Available Brodix Spec. Head

TUBE DIAMETER	COLL. DIA. LENGTH	STANDARD CHEVY #	CRATE MOTOR #	PRICE	SPREAD PORT #	13°, 15°, 16° CHEVY 18° #	PRICE	SB2 CHEVY #	PRICE
1 5/8" - 1 3/4"	3 1/2" x 8"	141-605LVG	141-605LVGCM	389.95	----	----	----	----	----
1 5/8" - 1 3/4"	3" x 8"	141-605LVG-3	141-605LVGCM-3	389.95	----	----	----	----	----
1 3/4" - 1 7/8"	3 1/2" x 9"	142-605LVG	142-605LVGCM	389.95	142-605LVGSP	142-605LVG18	449.95	142-605LVGSB2	499.95
1 7/8" - 2"	3 1/2" x 9"	143-605LVG	----	399.95	143-605LVGSP	143-605LVG18	459.95	143-605LVGSB2	509.95

Fits Mastersbilt, Warrior

505 OFF-SET

Available Brodix Spec. Head

TUBE DIAMETER	COLL. DIA. LENGTH	STANDARD CHEVY #	CRATE MOTOR	PRICE	SPREAD PORT #	13°, 15°, 16° CHEVY 18° #	PRICE	SB2 CHEVY #	PRICE
1 5/8" - 1 3/4"	3 1/2" x 8"	141-505LVG	141-505LVGCM	389.95	----	----	----	----	----
1 5/8" - 1 3/4"	3" x 8"	141-505LVG-3	141-505LVGCM-3	389.95	----	----	----	----	----
1 3/4" - 1 7/8"	3 1/2" x 9"	142-505LVG	142-505LVGCM	389.95	142-505LVGSP	142-505LVG18	449.95	142-505LVGSB2	499.95
1 7/8" - 2"	3 1/2" x 9"	143-505LVG	----	399.95	143-505LVGSP	143-505LVG18	459.95	143-505LVGSB2	509.95



Left Side

Chevy Dirt Late Model

Ceramic Coating add \$350.00
 CM = 604 Crate Motor



Right Side

Fits Rocket, Bernheisel

525 OFF-SET

Available Brodix Spec. Head

TUBE DIAMETER	COLL. DIA. LENGTH	STANDARD CHEVY #	CRATE MOTOR #	PRICE	SPREAD PORT #	13°, 15°, 16° CHEVY 18° #	PRICE	SB2 CHEVY #	PRICE
1 5/8" - 1 3/4"	3 1/2" x 8"	141-525LV	----	389.95	----	----	----	----	----
1 5/8" - 1 3/4"	3" x 8"	141-525LV-3	141-525LVCM-3	389.95	----	----	----	----	----
1 3/4" - 1 7/8"	3 1/2" x 9"	142-525LV	----	389.95	142-525LVSP	142-525LV18	449.95	142-525LVSB2	499.95
1 7/8" - 2"	3 1/2" x 9"	143-525LV	----	399.95	143-525LVSP	143-525LV18	459.95	143-525LVSB2	509.95

479-474-7529
 Fax # 479-474-2249
 Van Buren, AR
 www.SchoenfeldHeaders.com



Chevy LS1- LS7 Tri-Y Dirt Late Model

TUBE DIAMETER	COLLECTOR DIA.	LS1 - LS7 CHEVY #	PRICE
1 3/4" - 1 7/8"	3 1/2"	14260LVYLS3	839.95
1 5/8" - 1 3/4" - 1 7/8"	3"	14160LV3YLS3-3	899.95



Fits Bob Pierce, GRT, Rayburn, Masterbuilt, Larry Shaw, Rocket.
 Fits most other chassis.
 Temporary non-high temperature paint

Ford Tri-Y's available with R-45, Yates C3/D3, Dart N heads.

Ford Dirt Late Model

605 Offset Fits GRT, Stinger, TNT, Bob Pierce, Barry Wright, Bullitt, Larry Shaw, Raider, Warrior and Rayburn

525 Offset Fits Rocket, Bernheisel

505 Offset Fits Mastersbilt, Warrior

TUBE DIAMETER	COLLECTOR DIA./LENGTH	605 Offset	525 Offset	505 Offset	PRICE
		289-302-351 WINDSOR #	289-302-351 WINDSOR#	289-302-351 WINDSOR #	
1 5/8" - 1 3/4"	3 1/2" x 8"	341-605LVG	341-525LV	341-505LVG	469.95
1 5/8" - 1 3/4"	3" x 8"	341-605LVG-3	341-525LV-3	341-505LVG-3	469.95
1 3/4" - 1 7/8"	3 1/2" x 9"	342-605LVG	342-525LV	342-505LVG	469.95



Left Side

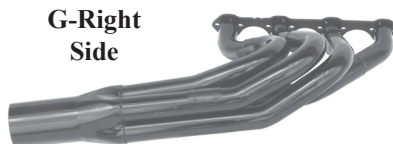

G-Right Side



525-Right Side

(Also available for wide Dart bolt pattern and Sportsman "N" Head)

Temporary non-high temperature paint

Chevy Boat/Marine

OVER-THE-TRANSON HEADERS

TUBE DIAMETER	COLLECTOR DIA./LENGTH	STANDARD CHEVY #	SPREAD PORT	PRICE
1 5/8"	3" x 13"	1092L	----	379.95
1 5/8" - 1 3/4"	3 1/2" x 13"	1092LV	----	439.95
1 5/8" - 1 3/4"	3" x 13"	1092LV-3	----	439.95
1 3/4" - 1 7/8"	3 1/2" x 13"	1094LV	----	439.95
1 7/8" - 2"	3 1/2" x 13"	1095LV	----	449.95
1 3/4" - 1 7/8"	3 1/2" x 13"	----	1094LVSP	499.95
1 7/8" - 2"	3 1/2" x 13"	----	1095LVSP	499.95



Temporary non-high temperature paint

Bolts and Gaskets included

Chassis Applications Midget Sprint Dirt Late Model IMCA Mod. Chassis Street Stock Stock Clip 180° Crossover Crossover Tractor/Derby Mufflers Elbow Applications Misc. Turnouts & Extensions X & Y Pipes U & J Bends Flanges/Gaskets Collectors Drag 4 Cyl. Dirt Mod.

Chevy Sprint Car Headers

New for ASCS Weld Tech ported heads

TUBE DIAMETER	COLLECTOR DIA./LENGTH	WELD TECH CHEVY #	PRICE
1 7/8"	3 1/2" x 13"	1055LWT	289.95
1 7/8" - 2"	3 1/2" x 13"	1055LVWT	349.95

Ceramic coating add \$350.00
Bolts and Gaskets included
Temporary non-high temperature paint
Welded to clear 4 inches from head to inside of header.



LS1

TUBE DIAMETER	COLLECTOR DIA./LENGTH	LS1 #	PRICE
1 5/8"	3" x 13"	1022L-LS1	319.95
1 5/8" - 1 3/4"	3 1/2" x 13"	1022LVLS1	379.95
1 3/4"	3 1/2" x 13"	1024L-LS1	319.95
1 3/4" - 1 7/8"	3 1/2" x 13"	1024LVLS1	379.95
1 7/8" - 2"	3 1/2" x 13"	1025LVLS1	379.95

SB2

TUBE DIAMETER	COLLECTOR DIA./LENGTH	SB2 CHEVY #	PRICE
1 3/4" - 1 7/8"	3 1/2" x 13"	1014LVSB2	459.95
1 7/8" - 2"	3 1/2" x 13"	1015LVSB2	459.95

Dyno/Sprint



Comes With 5/16" Flange
Bolts and Gaskets included
Temporary non-high temperature paint

Big Block Chevy

TUBE DIAMETER	COLLECTOR DIA./LENGTH	BIG BLOCK #	PRICE
2"	3 1/2" x 13"	2016A	419.95
2"	4" x 13"	2016	419.95
2 1/8"	4" x 13"	2017	429.95
2 1/4"	4" x 13"	2018	439.95
2 3/8"	4 1/2" x 13"	2019	459.95
2 3/8"	5" x 13"	2019-5	479.95

Big Block Ford

TUBE DIAMETER	COLLECTOR DIA./LENGTH	429-460 FORD #	PRICE
2"	4" x 13"	6016	419.95
2 1/8"	4" x 13"	6017	429.95

Dyno/Sprint



Temporary non-high temperature paint
Bolts and Gaskets included
Comes With 5/16" Flange

479-474-7529
 Fax # 479-474-2249
 Van Buren, AR
www.SchoenfeldHeaders.com



Chevy Sprint Car Headers

Improved to fit raised rail. 32" Length primaries - 18 ga. Tubing.
 Removes over 200° of bend compared to normal header to increase flow.

Available with CNC laser cut flanges to fit:
 Brodix 18° , Standard Chevy 18°, Allen Johnson,
 Pontiac 867, Stahl.

Welded to clear 4 inches from
 head to inside of header.

TUBE DIAMETER	COLLECTOR DIA./LENGTH	STANDARD CHEVY #	CRATE MOTOR#	SPREAD PORT/D.N #	ALL PRO GB 2300/2400 #	PRICE
1 5/8"	3" x 13"	1052L	1052LCM2	----	----	289.95
1 5/8" - 1 3/4"	3 1/2" x 13"	1052LV	----	----	----	349.95
1 5/8" - 1 3/4"	3" x 13"	1052LV-3	1052LVCM-3	----	----	349.95
1 3/4"	3 1/2" x 13"	1054L	----	----	----	289.95
1 3/4" - 1 7/8"	3 1/2" x 13"	1054LV	----	1054LVSP	----	349.95
1 7/8"	3 1/2" x 13"	1055L	----	1055LDN	1055LAP	289.95
1 7/8" - 2"	3 1/2" x 13"	1055LV	----	1055LVDN	1055LVAP	349.95
2"	3 1/2" x 13"	----	----	1056LDN	1056LAP	289.95



Straight tube Design

CM = 604 Crate Motor
 CM2 = 602 Crate Motor
 Ceramic coating add \$350.00
 Bolts and Gaskets included
 Armor 400 Gaskets available for D.N & All Pro
 Temporary non-high temperature paint

Chevy Sprint Tri-Y Headers

4 Into 2 Into 1 Tube Configuration for Increased Torque

TUBE DIAMETER	COLLECTOR DIAMETER	STANDARD CHEVY #	SPREAD PORT/D.N #	PRICE
1 5/8" - 1 3/4"	3"	1062VY	----	809.95
1 3/4" - 1 7/8"	3 1/2"	1064VY	1064VYSP	809.95
1 7/8" - 2"	3 1/2"	1065VY	1065VYDN	819.95

Bolts and Gaskets included
 Comes With 5/16" Flange
 Armor 400 Gaskets available for D.N & All Pro
 Temporary non-high temperature paint

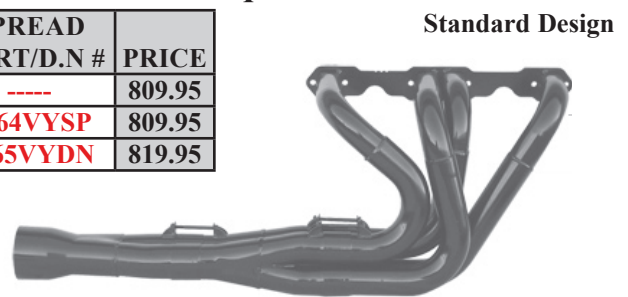

Standard Design

TUBE DIAMETER	COLLECTOR DIAMETER	STANDARD CHEVY #	SPREAD PORT/D.N #	PRICE
1 5/8" - 1 3/4"	3"	1022VY	----	809.95
1 3/4" - 1 7/8"	3 1/2"	1024VY	1024VYSP	809.95
1 7/8" - 2"	3 1/2"	1025VY	1025VYDN	819.95

Bolts and Gaskets included
 Comes With 5/16" Flange
 Armor 400 Gaskets available for D.N & All Pro

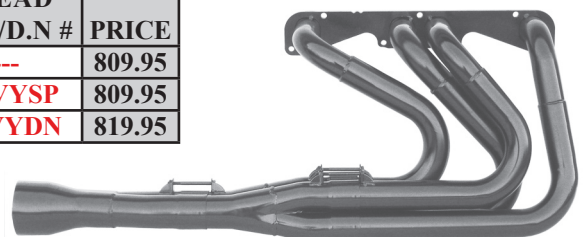

Forward Design

Chassis Applications | Midget | Sprint | Dirt Late Model | IMCA Mod. | Chassis | Street Stock | Stock Clip | 180° Crossover | Crossover | Tractor/Derby | Mufflers | Elbow Applications | Misc. | Turnouts & Extensions | X & Y Pipes | U & J Bends | Flanges/Gaskets | Drag | 4 Cyl. | Dirt Mod.

Chevy Sprint Car Headers

Improved to fit raised rail. 32" Primaries - 18 ga. Tubing.
 Forward Design for additional muffler clearance

Cab Forward Design

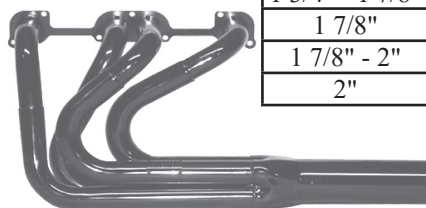

TUBE DIAMETER	COLLECTOR DIA./LENGTH	STANDARD CHEVY #	CRATE MOTOR#	SPREAD PORT/D.N #	ALL PRO GB23/24 #	PRICE
1 1/2" - 1 5/8"	3" x 13"	1021LV	----	----	----	349.95
1 5/8"	3" x 13"	1022L	1022LCM2	----	----	289.95
1 5/8" - 1 3/4"	3" x 13"	1022LV-3	1022LVCM-3	----	----	349.95
1 3/4"	3 1/2" x 13"	1024L	----	----	----	289.95
1 3/4" - 1 7/8"	3 1/2" x 13"	1024LV	----	1024LVSP	1024LVAP	349.95
1 7/8"	3 1/2" x 13"	1025L	----	1025LDN	1025LAP	289.95
1 7/8" - 2"	3 1/2" x 13"	1025LV	----	1025LVDN	1025LVAP	349.95
2"	3 1/2" x 13"	----	----	1026LDN	1026LAP	289.95

CM = 604 Crate Motor
 CM2 = 602 Crate Motor

Armor 400 Gaskets available for D.N & All Pro
 Bolts and Gaskets included

Standard Design

32" Primaries



TUBE DIAMETER	COLLECTOR DIA./LENGTH	STANDARD CHEVY #	CRATE MOTOR	SPREAD PORT/D.N #	ALL PRO GB23/24 #	PRICE
1 5/8" - 1 3/4"	3" x 13"	1012LV-3	1012LVCM-3	----	----	349.95
1 3/4"	3 1/2" x 13"	1014L	----	----	----	289.95
1 3/4" - 1 7/8"	3 1/2" x 13"	1014LV	----	1014LVSP	1014LVAP	349.95
1 7/8" - 2"	3 1/2" x 13"	1015LV	----	1015LVDN	1015LVAP	349.95

Ceramic coating add \$350.00

Bolts and Gaskets included

Chevy Asphalt Sprint

TUBE DIAMETER	COLLECTOR DIA./LENGTH	SPREAD PORT/D.N #	PRICE
1 3/4" - 1 7/8"	3 1/2" x 13"	1034LVSP	449.95
1 7/8" - 2"	3 1/2" x 13"	1035LVDN	449.95



Available for All Pro & Brodix GB heads
 Armor 400 Gaskets available for D.N & All Pro
 Bolts and Gaskets included

Tractor/Derby
 Dirt Mod.
 4 Cyl.
 Drag
 Crossover
 180° Crossover
 Collectors
 Flanges/Gaskets
 Stock Clip
 Street Stock
 U & J Bends
 Chassis
 X & Y Pipes
 Turnouts & Extensions
 Misc.
 Elbow Applications
 Mufflers
 Sprint
 Midget
 Chassis Applications



Mopar Sprint Car Headers

Straight tube design removes over 200° of bend compared to normal header to increase exhaust flow.

Straight tube Design

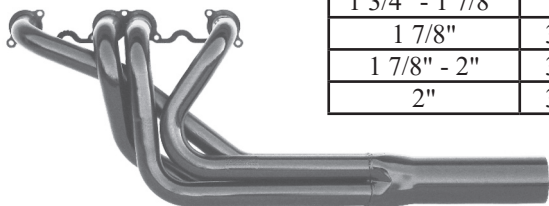

TUBE DIAMETER	COLLECTOR DIA./LENGTH	STANDARD MOPAR #	W-2 MOPAR #	W-9 MOPAR #	PRICE
1 5/8"	3" x 13"	4052L	4052LW2	----	389.95
1 5/8" - 1 3/4"	3 1/2" x 13"	4052LV	4052LVW2	----	449.95
1 5/8" - 1 3/4"	3" x 13"	4052LV-3	4052LVW2-3	----	449.95
1 3/4"	3 1/2" x 13"	4054L	4054LW2	----	389.95
1 3/4" - 1 7/8"	3 1/2" x 13"	4054LV	4054LVW2	----	449.95
1 7/8"	3 1/2" x 13"	----	----	4055LW9	399.95
1 7/8" - 2"	3 1/2" x 13"	----	----	4055LVW9	459.95
2"	3 1/2" x 13"	----	----	4056LW9	399.95

Ceramic coating add \$350.00
 Bolts and Gaskets included for small block standard Mopar
 Gaskets not included or available for W2, W9

Forward Design for additional muffler clearance

Cab Forward Design



TUBE DIAMETER	COLLECTOR DIA./LENGTH	STANDARD MOPAR #	W-2 MOPAR #	W-9 MOPAR #	PRICE
1 5/8"	3" x 13"	4022L	4022LW2	----	389.95
1 5/8" - 1 3/4"	3 1/2" x 13"	4022LV	4022LVW2	----	449.95
1 3/4"	3 1/2" x 13"	4024L	4024LW2	----	389.95
1 3/4" - 1 7/8"	3 1/2" x 13"	4024LV	4024LVW2	4024LVW9	449.95
1 7/8"	3 1/2" x 13"	----	----	4025LW9	399.95
1 7/8" - 2"	3 1/2" x 13"	----	----	4025LVW9	459.95
2"	3 1/2" x 13"	----	----	4026LW9	399.95

Bolts and Gaskets included for small block standard Mopar
 Gaskets not included or available for W2, W9
 Temporary non-high temperature paint

Ford Sprint Car Header

Forward Design for additional muffler clearance

TUBE DIAMETER	COLLECTOR DIA./LENGTH	289-302-351 WINDSOR#	DART/"N" SPORTSMAN#	PRICE
1 5/8"	3" x 13"	3022L	*3022LN	379.95
1 5/8" - 1 3/4"	3 1/2" x 13"	3022LV	*3022LVN	439.95
1 3/4"	3 1/2" x 13"	3024L	*3024LN	379.95
1 3/4" - 1 7/8"	3 1/2" x 13"	3024LV	*3024LVN	439.95

Cab Forward Design

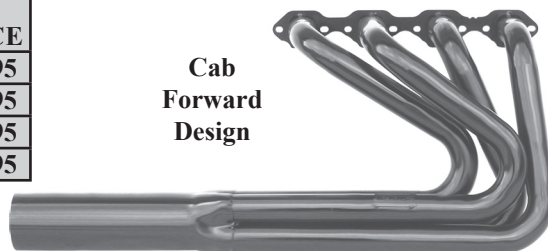

* Fits the wide Dart bolt pattern and Sportsman "N" head
 * Fits spec head, ASCS
 (Available for Edelbrock)

Chassis Applications | Midget | Sprint | Dirt Late Model | IMCA Mod. | Chassis | Street Stock | Stock Clip | 180° Crossover | Crossover | Tractor/Derby | Mufflers | Elbow Applications | Misc. | Turnouts & Extensions | X & Y Pipes | U & J Bends | Flanges/Gaskets | Drag | 4 Cyl. | Dirt Mod.

Toyota Midget Merge

TUBE DIAMETER	COLLECTOR DIA./STYLE	TOYOTA #	PRICE
1 3/4" - 1 7/8" - 2"	3" MERGE	T1034V3AMM	509.95
1 7/8" - 2"	3" MERGE	T1035VAMM	489.95
1 3/4" - 2"	3" MERGE	T1038V2AMM	509.95



UPSWEPT MERGE COLL.

Gaskets not included or available for Toyota
 Comes With 5/16" Flange
 Ceramic coating add \$225.00
 Temporary non-high temperature paint

Esslinger Midget Headers

Designed to fit ESSLINGER RSI engines

TUBE DIAMETER	COLLECTOR DIA./STYLE	UPSWEPT ESSLINGER#	PRICE
1 3/4" - 1 7/8" - 2"	3" MERGE	9174V3MMRU	509.95

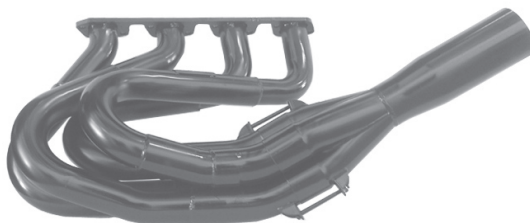

UPSWEPT MERGE

Headers come with 5/16" flange
 Gasket not included or available for Esslinger
 Ceramic coating add \$225.00
 Temporary non-high temperature paint

Designed to fit ESSLINGER ST/XT engines.

TUBE DIAMETER	COLLECTOR DIA./STYLE	ESSLINGER #	PRICE
1 3/4" - 1 7/8" - 2"	3" MERGE	9174V3MM	509.95

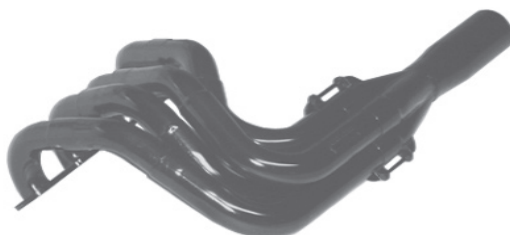

MERGE

Ceramic coating add \$225.00



Chevy Midget Upswept Merge

TUBE DIAMETER	COLLECTOR DIAMETER	SPREAD PORT #	PRICE
1 3/4" - 1 7/8"	3"	1074VAPMMU	489.95
1 7/8" - 2"	3"	1075VAPMMU	489.95

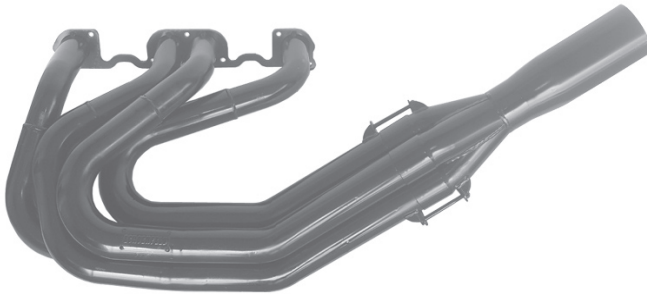

Mopar Available

Ceramic coating add \$225.00

Available for All Pro & Brodix GB heads
 Comes With 5/16" Flange
 Bolts and Gaskets included
 Armor 400 Gaskets available for D.N & All Pro
 Temporary non-high temperature paint

Chevy Midget Upswept Merge

TUBE DIAMETER	COLLECTOR DIAMETER	ALL PRO #	PRICE
1 3/4" - 1 7/8"	3"	1084VSPMM	489.95
1 7/8" - 2"	3"	1085VDNMM	489.95

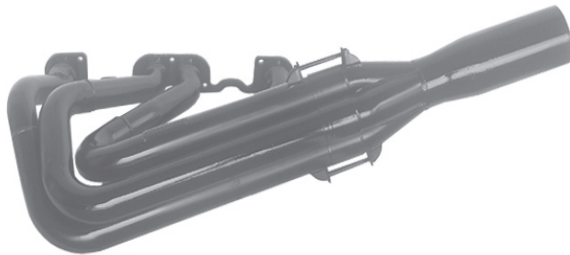

Ceramic coating add \$225.00
 Available for Brodix GB heads
 Comes With 5/16" Flange
 Bolts and Gaskets included
 Armor 400 Gaskets available for D.N & All Pro
 Available with Tri-Y collectors
 Temporary non-high temperature paint

Duratec/Ecotec Midget Merge

TUBE DIAMETER	COLLECTOR DIA./STYLE	RIGHT EXIT ECOTECH #	PRICE	TUBE DIAMETER	COLLECTOR DIA./STYLE	LEFT EXIT ECOTECH #	PRICE
1 3/4"	3" MERGE	1072EM	459.95	1 3/4" - 1 7/8" - 2"	3" MERGE	9074V3EM	509.95

Gasket not included
 or available for
 Duratec/Ecotec

TUBE DIAMETER	COLLECTOR DIA./STYLE	LEFT EXIT DURATECH #	PRICE
1 5/8" - 1 3/4" - 1 7/8"	3" MERGE	9373V3MM	509.95
1 3/4" - 1 7/8" - 2"	3" MERGE	9374V3MM	509.95

Comes With 5/16" Flange

Right side exit

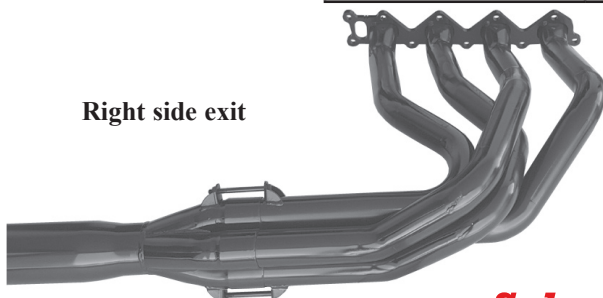

Left side exit



Tractor/Derby
 Crossover
 Drag 4 Cyl.
 Collectors
 180° Crossover
 Flanges/Gaskets
 Street Stock
 U & J Bends
 Chassis
 X & Y Pipes
 Turnouts & Extensions
 Misc.
 Sprint
 Midget
 Applications
 Elbow

Mopar Midget Upswept Merge

TUBE DIAMETER	COLLECTOR DIA.	SR 11 MOPAR #	PRICE
1 3/4" - 1 7/8"	3"	4074VHMU-OHC	509.95
1 3/4" - 1 7/8" - 2"	3"	4074V3HMU-OHC	509.95

Ceramic coating add \$225.00
 Gasket not included or available for SR 11
 Comes With 5/16" Flange
 Temporary non-high temperature paint

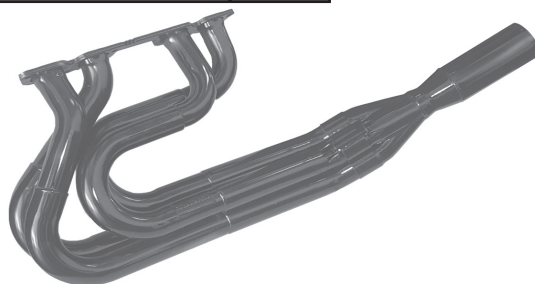

Ford Focus Midget Merge

TUBE DIAMETER	COLLECTOR DIA./STYLE	FOCUS #	PRICE
1 5/8" - 1 3/4"	3" MERGE	9132VFMMU	509.95

Ceramic coating add \$225.00
 Gasket not included or available for Ford Focus
 Comes With 5/16" Flange
 Temporary non-high temperature paint



Honda Midget Merge

TUBE DIAMETER	COLLECTOR DIA./STYLE	HONDA #	PRICE
1 3/4" - 1 7/8" - 2"	3" MERGE	9274V3MM	509.95

Comes With 5/16" Flange
 Gaskets not included or available for Honda
 Ceramic coating add \$225.00
 Temporary non-high temperature paint

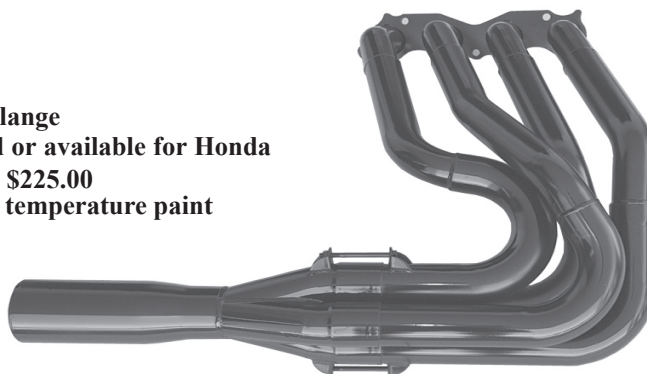



Lightning Sprint Tri-Y Header

TUBE DIAMETER	COLLECTOR DIAMETER	KAW ZX10 2011 - 2019 1000 #	PRICE
1 1/2" - 1 5/8"	2"	LS11532RVY	429.95

TUBE DIAMETER	COLLECTOR DIAMETER	SUZ GSXR 2007-2008 1000 #	PRICE
1 1/2" - 1 5/8"	2"	LS11732RVY	429.95

TUBE DIAMETER	COLLECTOR DIAMETER	SUZ GSXR 2005-2006 1000 #	PRICE
1 1/2" - 1 5/8"	2"	LS11732RVY-T	429.95

TUBE DIAMETER	COLLECTOR DIAMETER	YZ R1 2007 - 2008 1000 #	PRICE
1 1/2" - 1 5/8"	2"	LS11632RVY	429.95

TUBE DIAMETER	COLLECTOR DIAMETER	YZ R1 05-06 , 09-14 1000 #	PRICE
1 1/2" - 1 5/8"	2"	LS11632RVYR	429.95



Left side exit

Ceramic coating add \$225.00

Temporary non-high temperature paint

TUBE DIAMETER	COLLECTOR DIAMETER	KAW ZX10 2011 - 2019 1000 #	PRICE
1 1/2" - 1 5/8"	2"	LS11507RVY-R	429.95

TUBE DIAMETER	COLLECTOR DIAMETER	SUZ GSXR 2015-2019 1000 #	PRICE
1 1/2" - 1 5/8"	2"	LS11707RVYR-R	429.95

TUBE DIAMETER	COLLECTOR DIAMETER	SUZ GSXR 2005-2006 1000 #	PRICE
1 1/2" - 1 5/8"	2"	LS11707RVY-T	429.95

TUBE DIAMETER	COLLECTOR DIAMETER	YZ R1 2007 - 2008 1000 #	PRICE
1 1/2" - 1 5/8"	2"	LS11607RVY-R	429.95

TUBE DIAMETER	COLLECTOR DIAMETER	YZ R1 05-06 , 09-14 1000 #	PRICE
1 1/2" - 1 5/8"	2"	LS11607RVYR-R	429.95

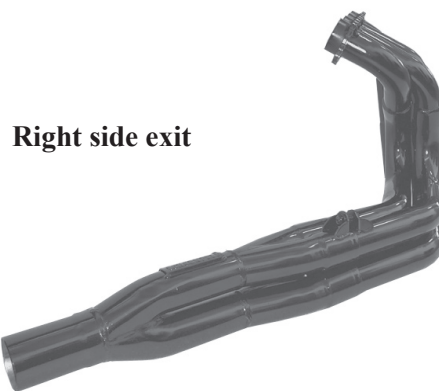

Right side exit

Ceramic coating add \$225.00

Temporary non-high temperature paint

TQ Midget Try-Y Header

TUBE DIAMETER	COLLECTOR DIAMETER	SUZUKI GSXR 4-2-1 COLL. #	PRICE
1 1/2" - 1 5/8"	1 3/4"	MT11713RVYR	429.95

TUBE DIAMETER	COLLECTOR DIAMETER	KAW. 636 4-2-1 COLL. #	PRICE
1 1/2" - 1 5/8"	1 3/4"	MT11513RVYR	429.95



Gaskets not included or available for TQ Midget

Ceramic coating add \$225.00

Temporary non-high temperature paint

Chassis Applications Mini Sprint Dirt Late Model IMCA Mod. Chassis Street Stock Stock Clip 180° Crossover Collectors Drag 4 Cyl. Tractor/Derby Mufflers Elbow Applications Turnouts & Extensions X & Y Pipes U & J Bends Flanges/Gaskets Crossover Drag 4 Cyl. Dirt Mod.

Micro Sprint Tri-Y Header

	BOSS	CONCEPT	D1	EDGE	FACTOR 1	HYPER	INTRUDER
HONDA	402	402	402	402	402	402	402
KAWASAKI	502	502C	502	502C	502C	502C	502
YAMAHA	602	602	602	602	602	602	602
SUZUKI	702C	702C	702C	702C	702C	702C	702C

C = 1" Closer to motor on head side

	PACE	PMP	SAWYER	SPIKE	STALLARD	UPFRONT	XXX
HONDA	402	402	402C	402	402	402	402
KAWASAKI	502	502	502	502	502C	502	502
YAMAHA	602	602	602	602	602C	602	602
SUZUKI	702C	702C	702C	702C	702C	702C	702C

Upswept Version

TUBE DIAMETER	COLLECTOR DIAMETER	SUZUKI GSXR 4-2-1 COLL. #	PRICE	TUBE DIAMETER	COLLECTOR DIAMETER	HONDA 600RR 4-2-1 COLL. #	PRICE
1 3/8" - 1 1/2"	1 3/4"	MS702RVYR-1CU	379.95	1 3/8" - 1 1/2"	1 3/4"	MS402RVYR-1U	379.95
				1 3/8" - 1 1/2"	1 3/4"	MS402RVYR-1CU	379.95

TUBE DIAMETER	COLLECTOR DIAMETER	YAMAHA R6R 4-2-1 COLL. #	PRICE	TUBE DIAMETER	COLLECTOR DIAMETER	YAMAHA R6 4-2-1 COLL. #	PRICE
1 3/8" - 1 1/2"	1 3/4"	MS602RVYR-1U	379.95	1 3/8" - 1 1/2"	1 3/4"	MS602RVY-1U	379.95
1 3/8" - 1 1/2"	1 3/4"	MS602RVYR-1CU	379.95	1 3/8" - 1 1/2"	1 3/4"	MS602RVY-1CU	379.95

TUBE DIAMETER	COLLECTOR DIAMETER	KAW. 636 4-2-1 COLL. #	PRICE	TUBE DIAMETER	COLLECTOR DIAMETER	KAW. 600 4-2-1 COLL. #	PRICE
1 3/8" - 1 1/2"	1 3/4"	MS502RVY-1U	379.95	1 3/8" - 1 1/2"	1 3/4"	MS502RVYR-1U	379.95
1 3/8" - 1 1/2"	1 3/4"	MS502RVY-1CU	379.95	1 3/8" - 1 1/2"	1 3/4"	MS502RVYR-1CU	379.95

Angled up 21°



02 Bung available add \$35.00

Ceramic coating add \$225.00

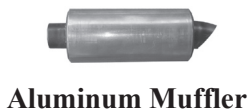

Temporary non-high temperature paint

Part # MS81721 - 1 3/4" Inlet \$120.95
 Part # MS101721 - 1 3/4" Inlet \$142.95
 Part # MS82022 - 2" Inlet \$120.95

Part # MS131722 - 1 3/4" Inlet \$65.95
 Part # MS132022 - 2" Inlet \$65.95



Micro Sprint Tri-Y Header

TUBE DIAMETER	COLLECTOR DIAMETER	YAMAHA R6 4-2-1 COLL. #	PRICE
1 3/8"	1 3/4"	MS600RY-6	379.95
1 3/8" - 1 1/2"	1 3/4"	MS603RVY-6	379.95

TUBE DIAMETER	COLLECTOR DIAMETER	YAMAHA R6R 4-2-1 COLL. #	PRICE
1 3/8" - 1 1/2"	1 3/4"	MS603RVYR-6	379.95

TUBE DIAMETER	COLLECTOR DIAMETER	KAW. 636 4-2-1 COLL. #	PRICE
1 3/8" - 1 1/2"	1 3/4"	MS503RVY-6	379.95

TUBE DIAMETER	COLLECTOR DIAMETER	KAW. 600 4-2-1 COLL. #	PRICE
1 3/8" - 1 1/2"	1 3/4"	MS503RVYR-6	379.95

TUBE DIAMETER	COLLECTOR DIAMETER	HONDA 600RR 4-2-1 COLL. #	PRICE
1 3/8" - 1 1/2"	1 3/4"	MS403RVYR-6	379.95

TUBE DIAMETER	COLLECTOR DIAMETER	SUZUKIGSXR 4-2-1 COLL. #	PRICE
1 3/8" - 1 1/2"	1 3/4"	MS703RVYR-6	379.95

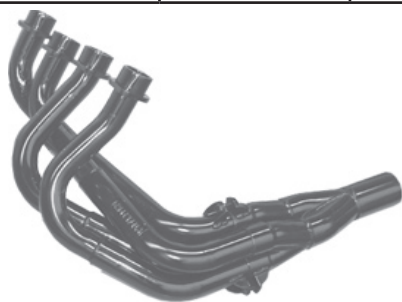

Left side exit



Elbow



Muffler

Ceramic coating add \$225.00

Available with 2" collector

Part # MS131722 - 1 3/4" Inlet \$65.95

Part # MS132022 - 2" Inlet \$65.95

Over The Top Micro Tri-Y

TUBE DIAMETER	COLLECTOR DIAMETER	YAMAHA R6 4-2-1 COLL. #	PRICE
1 3/8" - 1 1/2"	1 3/4"	MS613RVY-4	379.95

TUBE DIAMETER	COLLECTOR DIAMETER	YAMAHA R6R 4-2-1 COLL. #	PRICE
1 3/8" - 1 1/2"	1 3/4"	MS613RVYR-4	379.95

TUBE DIAMETER	COLLECTOR DIAMETER	KAW. 636 4-2-1 COLL. #	PRICE
1 3/8" - 1 1/2"	1 3/4"	MS513RVY-4	379.95

TUBE DIAMETER	COLLECTOR DIAMETER	KAW. 600 4-2-1 COLL. #	PRICE
1 3/8" - 1 1/2"	1 3/4"	MS513RVYR-4	379.95

TUBE DIAMETER	COLLECTOR DIAMETER	HONDA 600RR 4-2-1 COLL. #	PRICE
1 3/8" - 1 1/2"	1 3/4"	MS413RVYR-4	379.95

TUBE DIAMETER	COLLECTOR DIAMETER	SUZUKIGSXR 4-2-1 COLL. #	PRICE
1 3/8" - 1 1/2"	1 3/4"	MS713RVYR-4	379.95

Available with 2" collector

Ceramic coating add \$225.00

Part # MS81721 - 1 3/4" Inlet \$120.95

Part # MS101721 - 1 3/4" Inlet \$142.95

Part # MS82022 - 2" Inlet \$120.95



Left side exit



Aluminum Muffler



Steel Muffler

Part # MS131722 - 1 3/4" Inlet \$65.95

Part # MS132022 - 2" Inlet \$65.95

Temporary non-high temperature paint

Micro Sprint Merge Collector Header

More Low End Torque

2" Merge Coll. outlet
Comes with 45° Elbow
Three Step Long Primaries

Temporary non-high temperature paint
Ceramic coating add \$225.00

TUBE DIAMETER	COLLECTOR DIAMETER	HONDA 600RR MERGE COLL.#	PRICE
1 3/8" - 1 1/2" - 1 5/8"	2"	MS401RV3M-2	409.95

TUBE DIAMETER	COLLECTOR DIAMETER	KAW. 636 04-06 MERGE COLL.#	PRICE
1 3/8" - 1 1/2" - 1 5/8"	2"	MS501RV3M-2	409.95

TUBE DIAMETER	COLLECTOR DIAMETER	KAW. 636 13-UP MERGE COLL.#	PRICE
1 3/8" - 1 1/2" - 1 5/8"	2"	MS501RV3MX-2	409.95

TUBE DIAMETER	COLLECTOR DIAMETER	SUZUKI GSXR MERGE COLL.#	PRICE
1 3/8" - 1 1/2" - 1 5/8"	2"	MS701RV3MR-2	409.95

TUBE DIAMETER	COLLECTOR DIAMETER	YAMAHA R6R MERGE COLL.#	PRICE
1 3/8" - 1 1/2" - 1 5/8"	2"	MS601RV3MR-2	409.95

TUBE DIAMETER	COLLECTOR DIAMETER	YAMAHA R6 MERGE COLL.#	PRICE
1 3/8" - 1 1/2" - 1 5/8"	2"	MS601RV3M-2	409.95

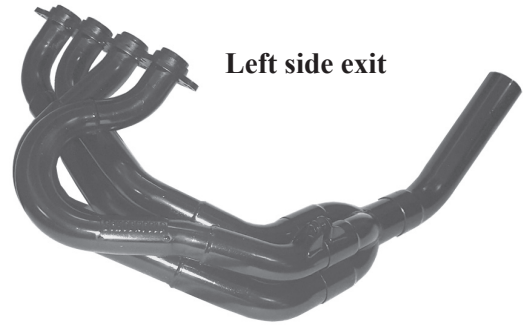

Mod-Lite Tri-Y Headers

TUBE DIAMETER	COLLECTOR DIAMETER	SUZUKI GSXR 2007-2016 1000 #	PRICE
1 1/2"	2"	ML11703RY	379.95
1 1/2" - 1 5/8"	2"	ML11703RVY	409.95

TUBE DIAMETER	COLLECTOR DIAMETER	SUZUKI GSXR 2001 - 2006 1000 #	PRICE
1 1/2"	2"	ML11703RY-T	379.95
1 1/2" - 1 5/8"	2"	ML11703RVY-T	409.95

TUBE DIAMETER	COLLECTOR DIAMETER	YAM. 2007-2008 R1 1000 #	PRICE
1 1/2" - 1 5/8"	2"	ML11603RVY	409.95

TUBE DIAMETER	COLLECTOR DIAMETER	YAM. 05,06 09-14 R1 1000 #	PRICE
1 1/2" - 1 5/8"	2"	ML11603RVYR	409.95

TUBE DIAMETER	COLLECTOR DIAMETER	KAW. 2004-2010 ZX10R 1000 #	PRICE
1 1/2" - 1 5/8"	2"	ML11503RVYR-T	409.95

TUBE DIAMETER	COLLECTOR DIAMETER	KAW. 2011-2019 ZX10R 1000 #	PRICE
1 1/2" - 1 5/8"	2"	ML11503RVYR	409.95

TUBE DIAMETER	COLLECTOR DIAMETER	HONDA CBR 1000 2012 CBR 1000 #	PRICE
1 1/2" - 1 5/8"	2"	ML11403RVYR	409.95



Part # MS82022 - 2" Inlet \$120.95

Part # MS132022 - 2" Inlet \$65.95



Temporary non-high temperature paint

Tractor/Derby
Dirt Mod.
4 Cyl. Drag
Collectors
Flanges/Gaskets
U & J Bends
X & Y Pipes
Turnouts & Extensions
Misc.
Elbow Applications
Mufflers
Crossover
180° Crossover
Stock Clip
Street Stock
Chassis
IMCA Mod.
Dirt Late Model
Micro Sprint
Chassis Applications

479-474-7529
 Fax # 479-474-2249
 Van Buren, AR
 www.SchoenfeldHeaders.com



Micro Sprint Tri-Y Header

YAMAHA

WITH 1 1/4" INSERT

TUBE DIAMETER	COLLECTOR DIAMETER	YAMAHA R6 4-2-1 COLL. #	PRICE
1 3/8"	1 3/4"	MS602RY-4	369.95
1 3/8"	1 3/4"	MS602RY-4C	369.95
1 3/8" - 1 1/2"	1 3/4"	MS602RVY-4	379.95
1 3/8" - 1 1/2"	1 3/4"	MS602RVY-4C	379.95

TUBE DIAMETER	COLLECTOR DIAMETER	YAMAHA R6 4-2-1 COLL. #	PRICE
1 3/8"	1 3/4"	MS602RIY-4	369.95
1 3/8"	1 3/4"	MS602RIY-4C	369.95
1 3/8" - 1 1/2"	1 3/4"	MS602RIVY-4	379.95
1 3/8" - 1 1/2"	1 3/4"	MS602RIVY-4C	379.95

TUBE DIAMETER	COLLECTOR DIAMETER	YAMAHA R6R 4-2-1 COLL. #	PRICE
1 3/8"	1 3/4"	MS602RYR-4	369.95
1 3/8"	1 3/4"	MS602RYR-4C	369.95
1 3/8" - 1 1/2"	1 3/4"	MS602RVYR-4	379.95
1 3/8" - 1 1/2"	1 3/4"	MS602RVYR-4C	379.95

TUBE DIAMETER	COLLECTOR DIAMETER	YAMAHA R6R 4-2-1 COLL. #	PRICE
1 3/8"	1 3/4"	MS602RIYR-4	369.95
1 3/8"	1 3/4"	MS602RIYR-4C	369.95
1 3/8" - 1 1/2"	1 3/4"	MS602RIVYR-4	379.95
1 3/8" - 1 1/2"	1 3/4"	MS602RIVYR-4C	379.95

KAWASAKI

TUBE DIAMETER	COLLECTOR DIAMETER	KAW. 636 4-2-1 COLL. #	PRICE
1 3/8"	1 3/4"	MS502RY-4	369.95
1 3/8"	1 3/4"	MS502RY-4C	369.95
1 3/8" - 1 1/2"	1 3/4"	MS502RVY-4	379.95
1 3/8" - 1 1/2"	1 3/4"	MS502RVY-4C	379.95

TUBE DIAMETER	COLLECTOR DIAMETER	KAW. 636 4-2-1 COLL. #	PRICE
1 3/8"	1 3/4"	MS502RIY-4	369.95
1 3/8"	1 3/4"	MS502RIY-4C	369.95
1 3/8" - 1 1/2"	1 3/4"	MS502RIVY-4	379.95
1 3/8" - 1 1/2"	1 3/4"	MS502RIVY-4C	379.95

HONDA

TUBE DIAMETER	COLLECTOR DIAMETER	HONDA 600RR 4-2-1 COLL. #	PRICE
1 3/8"	1 3/4"	MS402RYR-4	369.95
1 3/8"	1 3/4"	MS402RYR-4C	369.95
1 3/8" - 1 1/2"	1 3/4"	MS402RVYR-4	379.95
1 3/8" - 1 1/2"	1 3/4"	MS402RVYR-4C	379.95

TUBE DIAMETER	COLLECTOR DIAMETER	HONDA 600RR 4-2-1 COLL. #	PRICE
1 3/8"	1 3/4"	MS402RIYR-4	369.95
1 3/8"	1 3/4"	MS402RIYR-4C	369.95
1 3/8" - 1 1/2"	1 3/4"	MS402RIVYR-4	379.95
1 3/8" - 1 1/2"	1 3/4"	MS402RIVYR-4C	379.95

SUZUKI

TUBE DIAMETER	COLLECTOR DIAMETER	SUZUKI GSXR 4-2-1 COLL. #	PRICE
1 3/8"	1 3/4"	MS702RYR-4C	369.95
1 3/8" - 1 1/2"	1 3/4"	MS702RVYR-4C	379.95

TUBE DIAMETER	COLLECTOR DIAMETER	SUZUKI GSXR 4-2-1 COLL. #	PRICE
1 3/8"	1 3/4"	MS702RIYR-4C	369.95
1 3/8" - 1 1/2"	1 3/4"	MS702RIVYR-4C	379.95



Left side exit

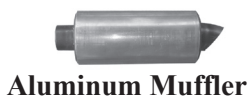

Aluminum Muffler



Steel Muffler

Part # MS81721 - 1 3/4" Inlet \$120.95
 Part # MS101721 - 1 3/4" Inlet \$142.95
 Part # MS82022 - 2" Inlet \$120.95

Part # MS131722 - 1 3/4" Inlet \$65.95
 Part # MS132022 - 2" Inlet \$65.95

Temporary non-high temperature paint

Available with 2" collector

Chassis Applications Micro Sprint Dirt Late Model IMCA Mod. Chassis Street Stock Stock Clip 180° Crossover Drag 4 Cyl. Tractor/Derby Dirt Mod. Mufflers Elbow Applications Misc. Turnouts & Extensions X & Y Pipes U & J Bends Flanges/Gaskets Collectors

Chevy D.I.R.T. Modified Headers

Fits Bicknell, TEO, Troyer

TUBE DIAMETER	COLL. DIA./LENGTH	STANDARD CHEVY #	CRATE MOTOR #	SPEC. HEAD #	PRICE
1 5/8"	3" x 8"	----	1122BUCM2	----	289.95
1 5/8" - 1 3/4"	3" x 8"	----	----	1122BVUSH-3	349.95
1 3/4" - 1 7/8"	3 1/2" x 9"	1124BVU	----	----	359.95

New Upswept Design

D.I.R.T Sportsman Division Spec Header 1122BCM, 1122BUCM2

D.I.R.T 358 Sportsman Division Spec Header
 1122BVSH-3, 1122BV, 1122BVUSH-3, 1124BVU



Elbow part # 3013 for 3"
 Elbow part # 3513 for 3 1/2"



Chevy D.I.R.T. Modified LS1 Tri-Y Headers

Fits Bicknell, TEO, Troyer

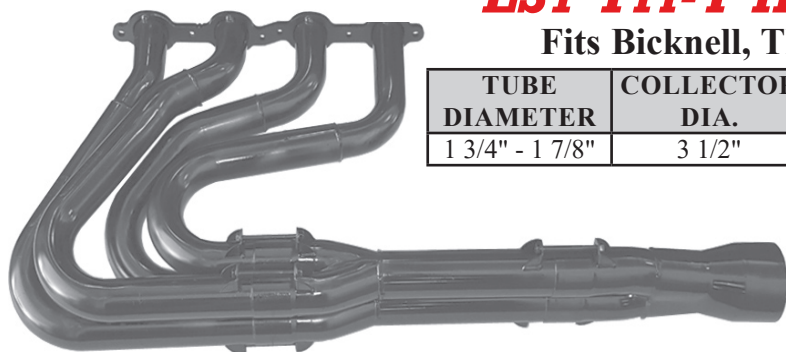

TUBE DIAMETER	COLLECTOR DIA.	LS1 #	PRICE
1 3/4" - 1 7/8"	3 1/2"	1124VYLS3	839.95

Ceramic Coating add \$350.00
 Bolts and Gaskets included
 Temporary non-high temperature paint

LT1/GEN 5 Truck 1973 - 1987 C-10 Truck

5/16" flange, 16 ga. primaries, O2 sensor bungs installed in collector, excellent spark plug access.

TUBE DIAMETER	COLLECTOR DIA./LENGTH	LT1/GEN 5 #	PRICE
1 3/4"	3" x 8"	1314LT1-3	379.95
1 7/8"	3 1/2" x 9"	1315LT1	469.95
1 7/8"	3" x 9"	1315LT1-3	469.95

LT1 Ceramic Coated Headers

TUBE DIAMETER	COLLECTOR DIA./LENGTH	LT1/GEN 5 #	PRICE
1 3/4"	3" x 8"	1314LT1-3-C	679.95

Temporary non-high temperature paint

Bolts and Gaskets included

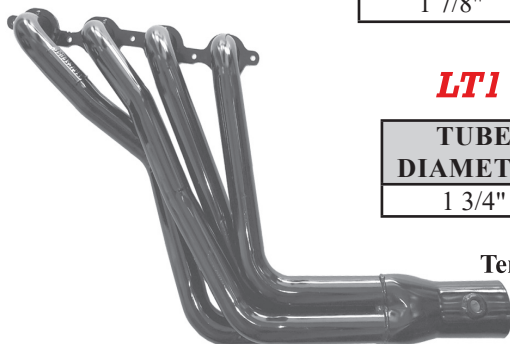



S-10 Chevy Truck Forward Exit

For S-10 conversion to a small block Chevy, Exits front lower fender
 1st Generation 1982-1993

TUBE DIAMETER	COLLECTOR DIA./LENGTH	STANDARD CHEVY #	PRICE	SPREAD PORT #	CHEVY 18° #	PRICE
1 3/4"	3 1/2" x 8"	1398A	509.95	----	----	----
1 3/4" - 1 7/8"	3 1/2" x 9"	1398VA	569.95	1398VASP	1398VA18	629.95
1 7/8" - 2"	3 1/2" x 9"	1399VA	629.95	1399VASP	1399VA18	689.95
1 7/8" - 2"	4" x 9"	1399VA-4	649.95	1399VASP-4	1399VA18-4	709.95

2nd Generation 1994-2004

TUBE DIAMETER	COLLECTOR DIA./LENGTH	STANDARD CHEVY #	PRICE	SPREAD PORT #	CHEVY 18° #	PRICE
1 3/4"	3 1/2" x 8"	1392A	509.95	----	----	----
1 3/4" - 1 7/8"	3 1/2" x 9"	1392VA	569.95	1392VASP	1392VA18	629.95
1 7/8" - 2"	3 1/2" x 9"	1393VA	629.95	1393VASP	1393VA18	689.95
1 7/8" - 2"	4" x 9"	1393VA-4	649.95	1393VASP-4	1393VA18-4	709.95

Temporary non-high temperature paint

Bolts and Gaskets included



Right Side

Left Side

LS1-LS7 Truck 1967-1999 OBS Truck

5/16" flange, 16 ga. primaries, O2 sensor bungs installed in collector, excellent spark plug access.

TUBE DIAMETER	COLLECTOR DIA./LENGTH	LS1 #	PRICE
1 3/4"	3" x 8"	1302LS1	379.95
1 7/8"	3 1/2" x 9"	1303LS1	469.95
1 7/8"	3" x 9"	1303LS1-3	469.95

LS1 Ceramic Coated Headers

TUBE DIAMETER	COLLECTOR DIA./LENGTH	LS1 #	PRICE
1 3/4"	3" x 8"	1302LS1-C	679.95



Temporary non-high temperature paint
 Bolts and Gaskets included
 Fits Chevy K10 Blazer 4 Wheel Drive

These products are intended for racing and off-road applications. Not legal for sale or use in the state of California, nor in states which have adopted California emission standards.

Chassis Applications | Midget Sprint | Dirt Late Model | IMCA Mod. | Chassis | Street Stock | Stock Clip | 180° Crossover | Crossover | Tractor/Truck | Mufflers | Elbow Applications | Misc. | Turnouts & Extensions | X & Y Pipes | U & J Bends | Flanges/Gaskets | Collectors | Drag 4 Cyl. | Dirt Mod.

Chevy Small Block Truck Fender Well

TUBE DIAMETER	COLLECTOR DIA./LENGTH	STANDARD CHEVY #	PRICE	18° CHEVY	PRICE	SPREAD PORT	PRICE
1 3/4"	3 1/2" x 13"	1346	469.95	----	----	----	----
1 3/4" - 1 7/8"	3 1/2" x 13"	1346V	539.95	1346V18	609.95	1346VSP	609.95
1 7/8" - 2"	3 1/2" x 13"	1347V	609.95	1347V18	669.95	1347VSP	669.95

Ceramic Coating add \$350.00
 Temporary non-high temperature paint
 5/16" flange, 16 ga. primaries, excellent spark plug access.
 Exits over steering shaft and frame.
 Fits straight or angle plug
 Will not fit 1967-1987 with stock heater box
 Will not fit manual clutch linkage
 Bolts and Gaskets included
 With evacuation tubes add \$60.00
 Clears 35" tires

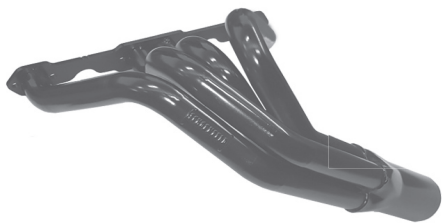

Chevy Big Block Truck Fender Well

TUBE DIAMETER	COLLECTOR DIA./LENGTH	BIG BLOCK CHEVY #	PRICE	WITH E-VACS	PRICE
2"	3 1/2" x 13"	2346	529.95	2346-E	579.95
2 1/8"	4" x 13"	2347	529.95	2347-E	579.95
2 1/4"	4" x 13"	2348	549.95	2348-E	599.95
2 3/8"	4 1/2" x 13"	2349	589.95	2349-E	639.95

396-454 fender well - 1968-1972 4WD
 1973-1987 but requires u-jointing the steering column unless a 3" body lift is used.

Bolts and Gaskets included
 Clears 35" tires
 Temporary non-high temperature paint

Ceramic Coating add \$350.00

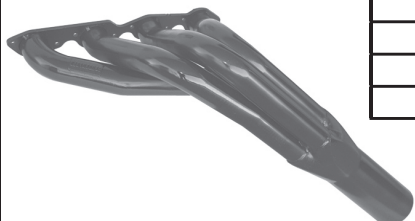

New! 1973-1988 Chevy Truck Headers New! LS1-LS7 Truck

16 ga. primaries, excellent spark plug access.
 5/16" Flange, Fits straight or angle plugs.
 Fits 4 wheel drive.

TUBE DIAMETER	COLLECTOR DIA./LENGTH	LS1 #	PRICE
1 3/4"	3" x 8"	1312LS1	379.95
1 7/8"	3 1/2" x 9"	1313LS1	469.95
1 7/8"	3" x 9"	1313LS1-3	469.95

Bolts and Gaskets included
 Temporary non-high temperature paint

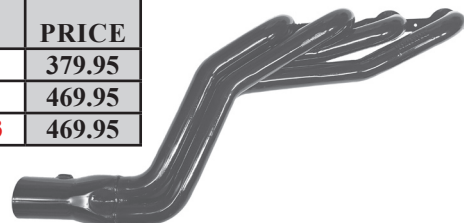

Must trim right side ear on transmission when using 4L80E

www.SchoenfeldHeaders.com

479-474-7529
 Fax # 479-474-2249
 Van Buren, AR
 www.SchoenfeldHeaders.com



Ceramic Coating add \$350.00

Truck Pulling

Small Block Chevy/LS1/Stahl – 28" Primaries - 5/16 Flange - 16 Ga. primaries

TUBE DIAMETER	COLLECTOR DIA./LENGTH	STANDARD CHEVY #	PRICE	CAB FORWARD #	PRICE
1 5/8"	3" x 8"	1512	249.95	1532	259.95
1 3/4"	3 1/2" x 8"	1514	279.95	1534	289.95
1 3/4"	3 1/2" x 8"	1514LS1	329.95	1534LS1	339.95
1 7/8"	3 1/2" x 9"	1515	319.95	1535	329.95
2"	3 1/2" x 9"	1516S	479.95	1536S	489.95

CAB FORWARD

Big Block Chevy – 31" Primaries - 5/16" Flange - 16 Ga. primaries

TUBE DIAMETER	COLLECTOR DIA./LENGTH	STANDARD CHEVY #	PRICE	CAB FORWARD #	PRICE
1 5/8"	3" x 8"	2512	329.95	2532	339.95
2"	4" x 9"	2516	419.95	2536	429.95
2 1/8"	4" x 10"	2517	419.95	2537	429.95
2 1/4"	4" x 10"	2518	429.95	2538	439.95
2 3/8"	4 1/2" x 10"	2519	509.95	2539	519.95

All Tractor Pull Available with Merge Coll.

With evacuation tubes add \$60.00

Ceramic Coating add \$350.00

429-460 Big Block Ford - 30" Primaries

Bolts and Gaskets included

May not fit with power brake booster. - 5/16" Flange

TUBE DIAMETER	COLLECTOR DIA./LENGTH	429-460 FORD #	PRICE
2"	4" x 9"	6516	429.95
2 1/8"	4" x 10"	6517	449.95

Cab forward available

Small Block Ford Windsor - 29" Primaries

TUBE DIAMETER	COLLECTOR DIA./LENGTH	289-302-351 WINDSOR #	*DART/"N" SPORTSMAN #	PRICE
1 5/8"	3" x 8"	3512	3512N	289.95
1 3/4"	3 1/2" x 8"	3514	3514N	299.95

Cab forward available

Big Block Mopar - 28" Primaries

Gaskets not included or available

TUBE DIAMETER	COLLECTOR DIA./LENGTH	MOPAR 440 #	PRICE
1 7/8"	3 1/2" x 9"	7515	429.95
2"	4" x 9"	7516	439.95

Demolition Derby

Chevy / Ford / Mopar (Exits thru hood)

5/16" Flange - 16 Ga. primaries

TUBE DIAMETER	STANDARD CHEVY #	WINDSOR 289-302-351 #	MOPAR 318-340-360 #	MOPAR 361-383-440 #	PRICE
1 5/8"	1522	----	----	----	159.95
1 5/8"	----	3522	4522	----	169.95
1 3/4"	----	----	----	7524	189.95

Chevy, Mopar - 27" from center of port to top of header

Ford - 24" from center of port to top of header



479-474-7529
 Fax # 479-474-2249
 Van Buren, AR
 www.SchoenfeldHeaders.com

IMCA Modified

CHASSIS	162-68	162-98H	11629H	152-152E	162	172-176	1101	1131	1137	1146	1155L	1155LBR	1176	1186	1166	1106
BANDIT							X					1155LBRF		X		X
BEAKBUILT											X			X		X
BILLSBUILT											1155LB			X		X
BMS							1101B			X				X		X
BOB PIERCE				X	X	X					1155LBW			X		X
CAM										X				X	X	X
DIAMOND								1131DS						1186DC		
DIRT BOSS	X	X	X		X									X	X	X
DIRTWORKS		X		X	X	X							X	X		X
DW-8		X		X	X	X							X	X		X
EDGE	X	X		X	X	X					1155LB		X	X		X
ELITE								1131EW						X		X
FLEXIFLYER	X		X	X	X								X			
FR 1				X		X								X		
GRT	X			X	X						1155LB			2		X
HARRIS	X	X	X	X	X	X	1101HG	1131H			1155LC		X	0		X
HOFFMAN				X	X	X	X			0			X	X	0	X
HORNADAY																
HOT CHASSIS				X	X	X							X	X		
HUGHES	X	X	X		X	X	1101HG	0		X			X	X	X	X
IMPRESSIVE											1155LB			X		X
IROC											1155LIRW					
J CAR															X	
JET RACING	X	X		X	X	X							X	X		X
KRAFT		X													X	
LARRY SHAW	X			X	X	X				X	1155LB		X	X	0	X
LETHAL											1155LBW					X
LG2											1155LBFW					X
LIGHTNING					X	X							X			
LONGHORN								1131EW								
LOU FEGERS					X								X	1		
MAD MAN											1155LB			X		X
MB CUSTOMS							X				1155LBFW					
MILLINIUM								1131MW								
MULLENS											1155LBW					
M & M													X	0		
PRO-CHASSIS	X			X	X	0							X	X		
QUICK					X									X		
RAGE								X		X				X	X	X
RAZOR			X				X	1131W		X				X		
ROCKET/RUHLMAN											1155LB					
SARDESON	X	X		X	X	X							X	X		
SIDEBITER	X	X	X		X		X				1155LG		X			
SKYROCKET		X	X		X	X			X							X
SMILEYS	X	X		X	X	X								X		
SPEEDWAY		X		X	X	X										
SWARTZ				X		X										
SYCLONE	X			X	X	X								X		X
TAYLOR M/S											X					X
THROWINDIRT														X	X	
TRE										X				X	X	
VICTORY	X	X	X		X	X					X			X		X
VICTORY CIRCLE												X				
WARRIOR				X	X											

Tractor/Derby
 Dirt Mod.
 4 Cyl.
 Drag
 Collectors
 180° Crossover
 Flanges/Gaskets
 Stock Clip
 Street Stock
 U & J Bends
 Chassis
 X & Y Pipes
 IMCA Mod.
 Turnouts & Extensions
 Misc.
 Sprint
 Midget
 Chassis Applications
 Mufflers



Flanges & Gaskets Small Block Chevy

Flanges price per each
 * = 5/16" thick

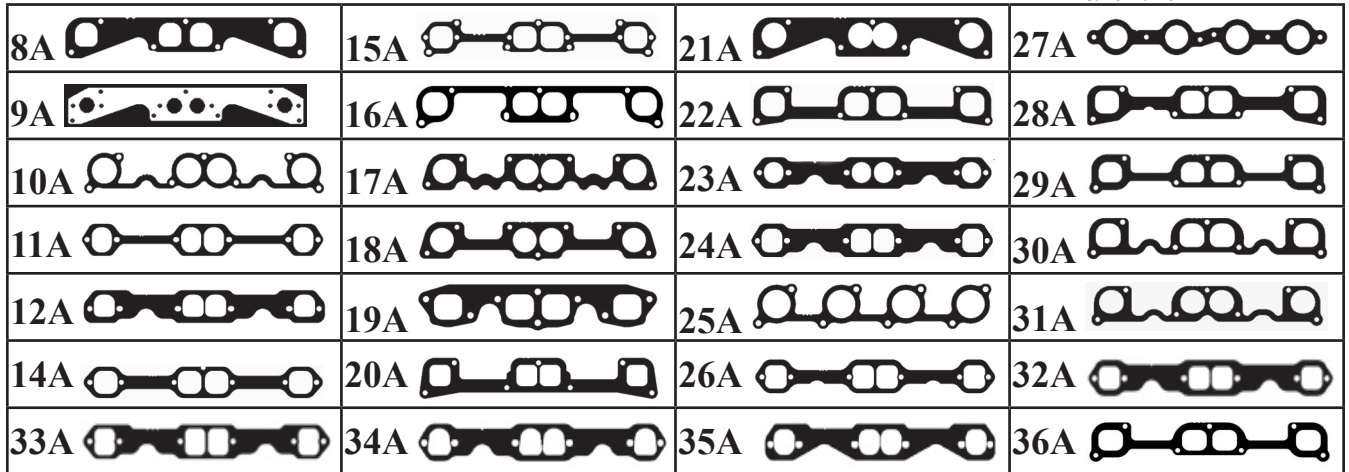

REF#	CYLINDER HEAD DESCRIPTION	TUBE DIA.	PORT SHAPE	STAMP/ CNC	FLANGE PART #	FLANGE PRICE	GASKET PART #	GASKET PRICE
*9A	23° SB ADAPTER KIT 3/8 THICK (2 PLATES, 2 INNER GASKETS & BOLTS)	1 1/4"	ROUND	CNC	0101K	170.95	01500	INCL.
*9A	23° SB ADAPTER (INNER ALUM.)	1 1/4"	ROUND	CNC	0101	65.95	01500	11.00
12A	CRATE MOTOR/FASTBURN-LT1/LT4	1 5/8"	D	CNC	0103	34.95	01560	11.00
*12A	CRATE MOTOR/FASTBURN-LT1/LT4	1 5/8"	D	CNC	0103-5	44.95	01560	11.00
12A	CRATE MOTOR/FASTBURN-LT1/LT4	1 3/4"	D	CNC	0104	34.95	01560	11.00
*12A	CRATE MOTOR/FASTBURN-LT1/LT4	1 3/4"	D	CNC	0104-5	44.95	01560	11.00
35A	CRATE MOTOR/602 / EQ HEAD	1 5/8"	SQUARE	CNC	01032	34.95	01562	11.00
*35A	CRATE MOTOR/602 / EQ HEAD	1 5/8"	SQUARE	CNC	01032-5	44.95	01562	11.00
11A	STANDARD SB (LITE) 265-400	1 3/4"	OVAL	CNC	0106	34.95	01510	11.00
11A	STANDARD SB (LITE) 265-400	1 7/8"	REC	CNC	0107	34.95	01510	11.00
23A	STANDARD SB 265-400	1 1/2"	ROUND	CNC	01091	34.95	01500	11.00
32A	STANDARD SB 265-400	1 5/8"	SQUARE	CNC	01101	34.95	01501	11.00
*32A	STANDARD SB 265-400	1 5/8"	SQUARE	CNC	01101-5	44.95	01501	11.00
34A	BRODIX TRACK 1/SPEC. HEAD	1 5/8"	SAP	CNC	01105	34.95	01570	11.50
24A	STANDARD SB 265-400	1 3/4"	D	CNC	01111	34.95	01511	11.00
*24A	STANDARD SB 265-400	1 3/4"	D	CNC	01111-5	44.95	01511	11.00
33A	STANDARD SB 265-400	1 7/8"	REC	CNC	0112	34.95	01510	11.00
*33A	STANDARD SB 265-400	1 7/8"	REC	CNC	0112-5	44.95	01510	11.00
*14A	SB 18° DEGREE/ PRO ACTION 14°- 6 BOLT	1 3/4"	SAP	CNC	0115-5	44.95	01540	12.75
*14A	SB 18° DEGREE/ PRO ACTION 14°- 6 BOLT	1 7/8"	SAP	CNC	0116-5	44.95	01540	12.75
*14A	SB 18° DEGREE/ PRO ACTION 14°- 6 BOLT	2"	SAP	CNC	0117-5	44.95	01540	12.75
8A	SB BRODIX SPREAD PORT(X)	1 3/4"	D	CNC	0119	34.95	01533	12.75
*8A	SB BRODIX SPREAD PORT(X)	1 3/4"	D	CNC	0119-5	44.95	01533	12.75
8A	SB BRODIX SPREAD PORT(X)	1 7/8"	D	CNC	0120	34.95	01533	12.75
*8A	SB BRODIX SPREAD PORT(X)	1 7/8"	D	CNC	0120-5	44.95	01533	12.75
10A	SB SPREAD PORT (LITE)(X)	1 3/4"	D	CNC	0121	34.95	01533	12.75
10A	SB SPREAD PORT (LITE)(X)	1 7/8"	D	CNC	0122	34.95	01532	12.75
10A	SB SPREAD PORT (LITE)(X)	2"	ROUND	CNC	0123	34.95	01531	12.75
29A	BRODIX ASCS/SUPRA	1 3/4"	SAP	CNC	01191	34.95	01530	12.75
*29A	BRODIX ASCS/SUPRA	1 3/4"	SAP	CNC	01191-5	44.95	01530	12.75
36A	BRODIX ASCS/WT	1 7/8"	SAP	CNC	01201	34.95	01530	12.75
30A	SB DOWN NOZZLE (SPREAD PORT)	1 7/8"	D	CNC	01251	34.95	01531	12.75
30A	SB DOWN NOZZLE (SPREAD PORT)	2"	ROUND	CNC	0126	34.95	01531	12.75
30A	SB DOWN NOZZLE (SPREAD PORT)	2 1/8"	ROUND	CNC	0127	34.95	01531	12.75
31A	SB DOWN NOZZLE ALL PRO - GB23/24	1 7/8"	SAP	CNC	01850	34.95	01532	12.75
*31A	SB DOWN NOZZLE ALL PRO - GB23/24	1 7/8"	SAP	CNC	01850-5	44.95	01532	12.75
31A	SB DOWN NOZZLE ALL PRO - GB23/24	2"	SAP	CNC	01860	34.95	01532	12.75
*31A	SB DOWN NOZZLE ALL PRO - GB23/24	2"	SAP	CNC	01860-5	44.95	01532	12.75

Flanges price per each
 SAP = Same as port
 * = 5/16" thick

(Small Block Chevy Cont.)

REF#	CYLINDER HEAD DESCRIPTION	TUBE DIA.	PORT SHAPE	STAMP/CNC	FLANGE PART #	FLANGE PRICE	GASKET PART #	GASKET PRICE
17A	SB ALAN JOHNSON 18 DEGREE	1 7/8"	ROUND	CNC	0130	34.95	----	----
17A	SB ALAN JOHNSON 18 DEGREE	2"	ROUND	CNC	0131	34.95	----	----
18A	SB 18° (OUTER, HOOKER ADAPTER)	1 7/8"	ROUND	CNC	0133	34.95	----	----
18A	SB 18° (OUTER, HOOKER ADAPTER)	2"	ROUND	CNC	0134	34.95	----	----
*19A	SB SB2	1 7/8"	SAP	CNC	0135-5	44.95	01590	14.75
*19A	SB SB2	2"	SAP	CNC	0136-5	44.95	01590	14.75
20A	SB PONTIAC HEAD (7 BOLT) # 867	1 3/4"	SAP	CNC	0142	34.95	----	----
20A	SB PONTIAC HEAD (7 BOLT) # 867	1 7/8"	SAP	CNC	0143	34.95	----	----
21A	SB STAHL (OUTER FLANGE)	1 3/4"	ROUND	CNC	0148	34.95	01520	12.75
*21A	SB STAHL (OUTER FLANGE)	1 7/8"	ROUND	CNC	0144-5	44.95	01520	12.75
*21A	SB STAHL (OUTER FLANGE)	2"	ROUND	CNC	0145-5	44.95	01520	12.75
21A	SB STAHL (OUTER FLANGE)	2 1/8"	ROUND	CNC	0146	34.95	01520	12.75
*22A	SB 18° BRODIX SPREAD PORT(C)	1 3/4"	SAP	CNC	0160-5	44.95	01530	12.75
22A	SB 18° BRODIX SPREAD PORT(C)	1 7/8"	SAP	CNC	0161	34.95	01530	12.75
*22A	SB 18° BRODIX SPREAD PORT(C)	1 7/8"	SAP	CNC	0161-5	44.95	01530	12.75
*15A	SB 18° DART (Dual Bolt Pattern)12.5,15,16,18	1 7/8"	SAP	CNC	0164-5	44.95	01540	12.75
15A	SB 18° DART (Dual Bolt Pattern)12.5,15,16,18	2"	SAP	CNC	0165-5	44.95	01540	12.75
25A	SBC BRODIX (BD)	1 7/8"	ROUND	CNC	0167	34.95	----	----
*25A	SBC BRODIX (BD)	1 7/8"	ROUND	CNC	0167-5	44.95	----	----
*25A	SBC BRODIX (BD)	2"	ROUND	CNC	0168-5	44.95	----	----
*25A	SBC BRODIX (BD)	2 1/8"	ROUND	CNC	0169-5	44.95	----	----
*25A	SBC BRODIX (BD)	2 1/4"	ROUND	CNC	0170-5	44.95	----	----
26A	SBC PRO-ACTION 23°	1 7/8"	SAP	CNC	0175	34.95	01511	11.00
*27A	SBC LS1	1 5/8"	ROUND	CNC	0177-5	44.95	01780	13.75
*27A	SBC LS1	1 3/4"	ROUND	CNC	0178-5	44.95	01780	13.75
*27A	SBC LS1	1 7/8"	ROUND	CNC	0179-5	44.95	01780	13.75
*27A	SBC LS3-LS7	1 3/4"	SAP	CNC	0178BR-5	44.95	01783	13.75
*27A	SBC LS3-LS7	1 7/8"	SAP	CNC	0179BR-5	44.95	01783	13.75
28A	SBC PRO-ACTION 14° - 7 BOLT	1 7/8"	SAP	CNC	0181	34.95	----	----
*16A	SBC BRODIX B10-10°,12°,13° - 4.5 WBORE	1 3/4"	SAP	CNC	01940-5	44.95	01545	12.75
*16A	SBC BRODIX B10-10°,12°,13° - 4.5 WBORE	1 7/8"	SAP	CNC	01941-5	44.95	01545	12.75

* = 5/16" thick

Big Block & 6 Cylinder Chevy



REF#	CYLINDER HEAD DESCRIPTION	TUBE DIA.	PORT SHAPE	STAMP/CNC	FLANGE PART #	FLANGE PRICE	GASKET PART #	GASKET PRICE
*30B	BB 396-454	1 5/8"	ROUND	CNC	0208-5	44.95	0250	12.75
*30B	BB 396-454	1 7/8"	ROUND	CNC	0210-5	44.95	02510	12.75
*30B	BB 396-454	2"	SAP	CNC	0211-5	44.95	02510	12.75
*30B	BB 396-454	2 1/8"	ROUND	CNC	0212-5	44.95	02520	12.75
*30B	BB 396-454	2 1/4"	ROUND	CNC	0213-5	44.95	02520	12.75
*30B	BB 396-454	2 3/8"	ROUND	CNC	0214-5	44.95	02520	12.75
*30B	BB 396-454	2 1/2"	ROUND	CNC	0215-5	44.95	02520	12.75
31B	V-6 18 DEGREE	1 3/4"	SAP	CNC	0830	44.95	----	----
31B	V-6 18 DEGREE	1 7/8"	SAP	CNC	0832	44.95	----	----
32B	V-6 STANDARD	1 5/8"	SAP	CNC	08311	44.95	08341	14.00
32B	V-6 STANDARD	1 3/4"	OVAL	CNC	08330	44.95	08341	14.00







* = 5/16" thick

SAP = Same as port

39C  **Big Block Ford** **37C** 





REF#	CYLINDER HEAD DESCRIPTION	TUBE DIA.	PORT SHAPE	STAMP/ CNC	FLANGE PART #	FLANGE PRICE	GASKET PART #	GASKET PRICE
*39C	390-428 FE	2 1/8"	SAP	CNC	0606	44.95	----	----
*37C	429-460 FORD	1 7/8"	SAP	CNC	*0611	44.95	06511	13.75
*37C	429-460 FORD	2"	SAP	CNC	*0612	44.95	06511	13.75
*37C	429-460 FORD	2 1/8"	SAP	CNC	*0613	44.95	06511	13.75
*37C	429-460 FORD COBRA	2 1/8"	SAP	CNC	*0613C	44.95	06511	13.75





V-6 & 4 Cylinder Ford & Toyota



38D  **39D**  **40D**  **41D** 

REF#	CYLINDER HEAD DESCRIPTION	TUBE DIA.	PORT SHAPE	STAMP/ CNC	FLANGE PART #	FLANGE PRICE	GASKET PART #	GASKET PRICE
38D	SVO RACING HEAD (ALUM.) V-6	1 3/4"	SAP	CNC	0630	34.95	----	----
39D	2000cc (4 CYLINDER)	1 1/2"	OVAL	CNC	FF20	34.95	FG20	13.95
39D	2000cc (4 CYLINDER)	1 5/8"	OVAL	CNC	FF21	34.95	FG20	13.95
40D	2300cc (4 CYLINDER)	1 1/2"	OVAL	CNC	FF23	34.95	FG23	13.95
40D	2300cc (4 CYLINDER)	1 5/8"	OVAL	CNC	FF24	34.95	FG23	13.95
*41D	TOYOTA V-8	1 7/8"	SAP	CNC	TF41	44.95	----	----

Small Block Ford

33E  **34E**  **35E**  **36E** 

37E  **38E**  **39E**  **40E** 

41E  **42E** 

REF#	CYLINDER HEAD DESCRIPTION	TUBE DIA.	PORT SHAPE	STAMP/ CNC	FLANGE PART #	FLANGE PRICE	GASKET PART #	GASKET PRICE
33E	289W - 351W / GT40	1 5/8"	SAP	CNC	0306	34.95	03500	12.75
33E	289W - 351W / GT40	1 3/4"	SAP	CNC	0309	34.95	03500	12.75
*34E	289W - 351W / GT40	1 3/4"	SAP	CNC	0309-5	44.95	03500	12.75
34E	SVO "N" / DART WIDE BOLTS - SPEC	1 5/8"	SAP	CNC	0311	34.95	03520	12.75
*34E	SVO "N" / DART WIDE BOLTS - SPEC	1 5/8"	SAP	CNC	0311-5	44.95	03520	12.75
34E	SVO "N" / DART WIDE BOLTS - SPEC	1 3/4"	SAP	CNC	0312	34.95	03520	12.75
*34E	SVO "N" / DART WIDE BOLTS - SPEC	1 3/4"	SAP	CNC	0312-5	44.95	03520	12.75
34E	SVO "N" / DART WIDE BOLTS - SPEC	1 7/8"	SAP	CNC	03131	34.95	03520	12.75
*34E	SVO "N" / DART WIDE BOLTS - SPEC	1 7/8"	SAP	CNC	03131-5	44.95	03520	12.75
41E	BRODIX CNC / STS T1	1 5/8"	SAP	CNC	03155	34.95	03520	12.75
41E	BRODIX CNC / STS T1	1 3/4"	SAP	CNC	03156	34.95	03520	12.75
41E	BRODIX CNC / STS T1	1 7/8"	SAP	CNC	03157	34.95	03520	12.75
42E	EDELBROCK/MCGUNEGILL	1 3/4"	SAP	CNC	03151	34.95	03520	12.75
*42E	EDELBROCK/MCGUNEGILL	1 3/4"	SAP	CNC	03151-5	44.95	03520	12.75
34E	EDELBROCK	1 7/8"	SAP	CNC	0316	34.95	03520	12.75
39E	EDELBROCK / KUNTZ	1 7/8"	SAP	CNC	0318	34.95	----	----
40E	CRATE MOTOR/Z304	1 5/8"	SAP	CNC	0320	34.95	03520	12.75
*40E	CRATE MOTOR/Z304	1 5/8"	SAP	CNC	0320-5	44.95	03520	12.75
40E	CRATE MOTOR/Z304	1 3/4"	SAP	CNC	0321	34.95	03520	12.75
35E	351 CLEVELAND (2 BARREL) 351	1 3/4"	OVAL	STAMP	0510	34.95	----	----
36E	CLEVELAND (4 BARREL) SVO	2"	SAP	CNC	0512	34.95	----	----
37E	SVO C3/C33 YATES (ALUM.)	1 7/8"	SAP	CNC	0602	34.95	----	----
38E	SVO D3 YATES (ALUM.)	1 7/8"	ROUND	CNC	0603	34.95	----	----
38E	SVO D3 YATES (ALUM.)	2"	ROUND	CNC	0604	34.95	----	----

Mopar

SAP = Same as port

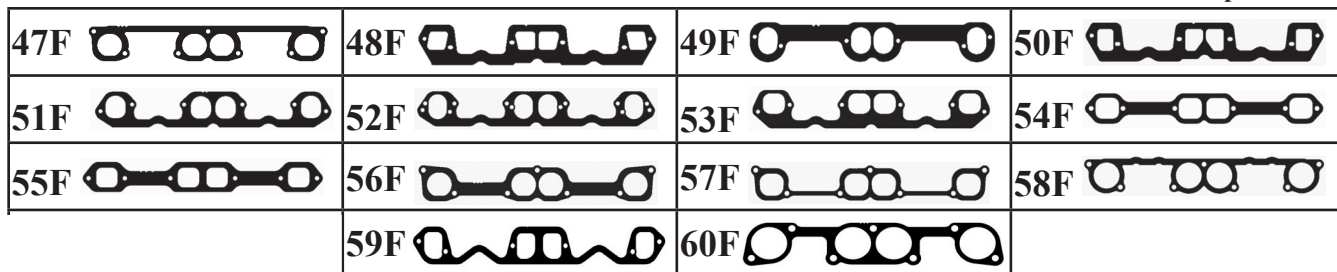

REF#	CYLINDER HEAD DESCRIPTION	TUBE DIA.	PORT SHAPE	STAMP/CNC	FLANGE PART #	FLANGE PRICE	GASKET PART #	GASKET PRICE
58F	W-9 RAISED INTAKE (LITE)	1 7/8"	SAP	CNC	0404	34.95	----	----
58F	W-9 RAISED INTAKE (LITE)	2"	ROUND	CNC	0405	34.95	----	----
50F	273-318-340-360	1 5/8"	SAP	CNC	0410	34.95	04500	12.75
50F	273-378-340-360	1 3/4"	SAP	CNC	0411	34.95	04500	12.75
51F	W-2 (4 3/4" CNTR. BOLTS)	1 3/4"	D	CNC	0414	34.95	----	----
52F	W-2 (4" OR 4 3/4" CNTR. BOLTS)	1 5/8"	OVAL	CNC	0417	34.95	----	----
52F	MAGNUM EQ	1 5/8"	SAP	CNC	0417R	34.95	----	----
52F	W-2 (4" OR 4 3/4" CNTR. BOLTS)	1 3/4"	OVAL	CNC	0418	34.95	----	----
53F	W-5	1 3/4"	SAP	CNC	0420	34.95	----	----
54F	W-7	1 7/8"	SAP	CNC	0423	34.95	----	----
56F	W-9	1 7/8"	ROUND	CNC	0407	34.95	----	----
56F	W-9	2"	SAP	CNC	0408	34.95	----	----
47F	W-9 (LITE)	1 7/8"	SAP	CNC	0455	34.95	----	----
57F	W-9 (LITE)	2"	SAP	CNC	0426	34.95	----	----
55F	440 WEDGE (INDY)	1 7/8"	SAP	CNC	0427	34.95	----	----
55F	440 WEDGE (INDY)	2"	SAP	CNC	0428	34.95	----	----
55F	440 WEDGE (INDY)	2 1/8"	SAP	CNC	0430	34.95	----	----
55F	440 WEDGE (INDY)	2 1/4"	SAP	CNC	0431	34.95	----	----
48F	MAGNUM CRATE MOTOR	1 5/8"	SAP	CNC	0432	34.95	----	----
55F	440 IRON/383	1 3/4"	SAP	CNC	0434	34.95	----	----
55F	440 IRON/383	1 7/8"	SAP	CNC	0435	34.95	----	----
55F	440 IRON/383	2"	SAP	CNC	0436	34.95	----	----
49F	MOPAR W2 (B1/BA-ASCS)	1 3/4"	OVAL	CNC	0441	34.95	----	----
60F	P 7 MOPAR	1 7/8"	SAP	CNC	04501	34.95	----	----

O2 Bung

BUNG PART #	BUNG PRICE EA.	SIZE
100-14	7.00	18 mm

INSTALLED

BUNG PART #	BUNG PRICE SET	SIZE
100-15	60.00	18 mm

INSTALLED

BUNG PART #	BUNG PRICE EACH	SIZE
100-15-1	35.00	18 mm



Flanges & Gaskets

FLANGE PART #	FLANGE PRICE	FLANGE ID.	BOLT HOLES	GASKET PART #	GASKET PRICE
250CR	4.25	2 1/2"	3	250CG	5.50
300CR	4.25	3"	3	300CG	5.50
350CR	7.95	3 1/2"	3	350CG	5.50

479-474-7529
 Fax # 479-474-2249
 Van Buren, AR
 www.SchoenfeldHeaders.com



Reducers

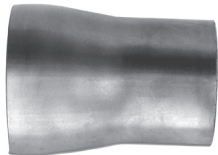

Header Bolts

5/16" Head



INLET	OUTLET	PART#	PRICE
2" I.D.	3" O.D.	2030	14.95
2 1/4" I.D.	3" O.D.	2230	14.95
2 1/2" I.D.	2" O.D.	2520	11.95
2 1/2" I.D.	3" O.D.	2530ID	11.95
3" I.D.	2 1/2" O.D.	2530	11.95
3 1/2" I.D.	2 1/2" O.D.	2535	13.95
2 3/4" I.D.	3" O.D.	2730	13.95
3" I.D.	2" O.D.	3020	15.95
3" I.D.	2 1/4" O.D.	3022	15.95
3 1/2" I.D.	3" O.D.	3035	11.95
3" I.D.	3 1/2" O.D.	3530	11.95
3" I.D.	3" O.D.	3030	11.95
3" I.D.	3" I.D.	3030ID	11.95
3 1/2" I.D.	3 1/2" O.D.	3535	11.95
3 1/2" I.D.	3 1/2" I.D.	3535ID	11.95
3 1/2" I.D.	4" O.D.	3540	12.95
3" I.D.	4" O.D.	4030	20.95
4" I.D.	3 1/2" O.D.	4035	13.95

DESCRIPTION	PART #	PRICE
3/8" x 3/4" x 5/16" HEX HEAD, 12 PACK	3006-12	10.95
3/8" x 3/4" x 5/16" HEX HEAD, 14 PACK	3006-14	11.95
3/8" x 3/4" x 5/16" HEX HEAD, 16 PACK	3006-16	12.95
3/8" x 3/4" FLAT HEAD, 12 PACK	3001-12	12.95
3/8" x 1" x 5/16" HEX HEAD, 12 PACK	3002-12	15.25
5/16" x 3/4" x 3/8" HEX HEAD (MOPAR) - 12 PACK	3003-12	12.95
8mm x 22mm x 5/16" (LS1-LS7) 12 PACK	3004-12	12.50
8mm x 22mm x 5/16" (2000 PINTO) 8 PACK	3004-8	9.95
10mm x 22mm x 5/16" (2300 PINTO) 8 PACK	3005-8	9.95

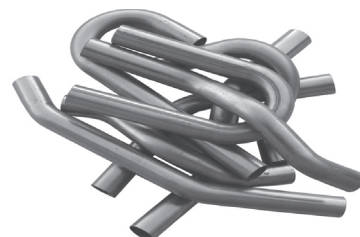

Misc. Bends

Approx. 36 Ft.
 18ga. Mild Steel



U & J Mandrel Bends

18 GAUGE TUBING					16 GAUGE TUBING		
U BENDS #	J BENDS #	PRICE	TUBE DIA.	BEND RADIUS	U BENDS #	J BENDS #	PRICE
013718U	013718J	13.00	1 3/8"	2 1/2"	----	----	----
015018U	015018J	13.00	1 1/2"	2 1/2"	015016U	015016J	15.00
016218U	016218J	13.00	1 5/8"	2 1/2"	016216U	016216J	15.00
017518U	017518J	13.00	1 3/4"	2 1/2"	017516U	017516J	16.00
017518U-40	017518J-40	15.00	1 3/4"	4"	017516U-40	017516J-40	17.00
018718U	018718J	13.00	1 7/8"	3"	018716U	018716J	17.00
018718U-40	018718J-40	13.00	1 7/8"	4"	018716U-40	018716J-40	17.00
020018U	020018J	14.00	2"	3"	----	----	----
020018U-40	020018J-40	14.00	2"	4"	----	----	----
021218U	021218J	17.00	2 1/8"	3"	----	----	----
021218U-35	021218J-35	17.00	2 1/8"	3 1/2"	----	----	----
022518U	022518J	19.00	2 1/4"	3 1/2"	022516U	022516J	19.00
023718U	023718J	22.00	2 3/8"	3 1/2"	----	----	----
025018U	025018J	25.00	2 1/2"	4"	025016U	025016J	25.00

TUBE DIA.	PART#	PRICE
1 3/8"	MB137	189.95
1 1/2"	MB150	189.95
1 5/8"	MB162	189.95
1 3/4"	MB175	199.95
1 7/8"	MB187	199.95
2"	MB200	219.95
2 1/8"	MB212	239.95
2 1/4"	MB225	289.95
2 3/8"	MB237	309.95

16ga. Mild Steel

TUBE DIA.	PART #	PRICE
1 1/2"	MB150-16	209.95
1 5/8"	MB162-16	209.95
1 3/4"	MB175-16	229.95
1 7/8"	MB187-16	229.95
2 1/4"	MB225-16	319.95

U Bends have 9" legs & J Bends have 3" and 15" legs (Straight Part) -- 2 1/4" U Bends have 7 1/2" legs

Tractor/Derby | Crossover | 180° Crossover | Stock Clip | Street Stock | Chassis | IMCA Mod. | Dirt Late Model | Sprint | Midget | Chassis Applications | Mufflers
 4 Cyl. | Drag | Collectors | Flanges/Gaskets | U & J Bends | X & Y Pipes | Turnouts & Extensions | Misc. | Elbow Applications

Collectors



SLIPS OVER	COLL DIA.	# OF TUBES	STYLE 3 PART #	STYLE 6 PART #	STYLE 8 PART #	STYLE 9 PART #	STYLE 9H #	PRICE
1 1/2"	3"	4	SO53043	SO53046	SO53048	SO53049	SO53049H	53.95
1 5/8"	3"	4	SO63043	SO63046	SO63048	SO63049	SO63049H	53.95
1 5/8"	3 1/2"	4	SO63543	SO63546	SO63548	SO63549	SO63549H	53.95
1 3/4"	3 1/2"	4	SO73543	SO73546	SO73548	SO73549	SO73549H	53.95
1 7/8"	3 1/2"	4	SO83543	SO83546	SO83548	SO83549	SO83549H	53.95



SLIP-OVER



Style 1



WELD-ON

*-2 PART #	-2 PRICE	-1 PART #	-1 PRICE	SLIPS OVER	COLL. DIA.	# OF TUBES	PART #	COLL. LEN.	PRICE
----	----	ASK	49.95	1 1/2"	3"	3	WO53030	8"	17.95
----	----	ASK	49.95	1 5/8"	3"	3	WO63030	8"	17.95
----	----	ASK	49.95	1 3/4"	3"	3	WO73030	8"	17.95
----	----	ASK	49.95	1 7/8"	3"	3	WO83030	8"	17.95
----	----	ASK	49.95	2"	3"	3	WO03030	8"	17.95
SO53042	54.95	SO53041	49.95	1 1/2"	3"	4	WO53040	8"	17.95
SO63042	54.95	SO63041	49.95	1 5/8"	3"	4	WO63040	8"	17.95
SO73042	54.95	SO73041	49.95	1 3/4"	3"	4	WO73040	8"	17.95
SO63542	54.95	SO63541	49.95	1 5/8"	3 1/2"	4	WO63540	8"	17.95
SO73542	58.95	SO73541	49.95	1 3/4"	3 1/2"	4	WO73540	8"	18.95
SO83542	58.95	SO83541	49.95	1 7/8"	3 1/2"	4	WO83540	9"	19.95
SO03542	58.95	SO03541	50.95	2"	3 1/2"	4	WO03540	9"	19.95
----	----	----	----	2 1/8"	3 1/2"	4	WO13540	9"	24.95
----	----	SO04041	59.95	2"	4"	4	WO04040	9"	24.95
----	----	SO14041	59.95	2 1/8"	4"	4	WO14040	10"	25.95
----	----	----	----	2 1/4"	4"	4	WO24040	10"	27.95

Merge Collectors



Temporary non-high temperature paint

SLIPS OVER	MERGE DIAMETER	OUTLET DIAMETER	PART #	PRICE
1 3/4"	2 1/2"	3"	SOM72530	229.95
1 7/8"	2 1/2"	3"	SOM82530	229.95
2"	2 1/2"	3"	SOM02530	229.95
1 3/4"	2 3/4"	3 1/2"	SOM72735	229.95
1 7/8"	2 3/4"	3 1/2"	SOM82735	229.95
2"	2 3/4"	3 1/2"	SOM02735	229.95
2 1/8"	2 3/4"	3 1/2"	SOM12735	239.95
2 1/4"	2 3/4"	3 1/2"	SOM22735	239.95
2 1/4"	3 1/4"	4"	SOM23240	239.95
2 3/8"	3 1/2"	4"	SOM33240	259.95

Chassis Applications | Midget | Sprint | Dirt Late Model | IMCA Mod. | Chassis | Street Stock | Stock Clip | 180° Crossover | Crossover | Tractor/Derby
 Miffers | Elbow Applications | Misc. | Turnouts & Extensions | X & Y Pipes | U & J Bends | Flanges/Gaskets | Collectors | Drag 4 Cyl. | Dirt Mod.



2 Into 1 Y Pipes (Collectors)



2 Into 1 Y Pipe 60°



2 Into 1 Y Pipe

SLIPS OVER	COLL. DIA.	ANGLE	PART #	PRICE
1 5/8"	1 7/8"	----	Y16S1818	99.95
1 3/4"	2"	----	Y17S2020	99.95
1 7/8"	2 1/8"	----	Y18S2121	99.95
1 7/8"	2 1/2" - 3"	----	Y18S2530	109.95
2"	2 1/4"	----	Y20S2222	99.95
2"	2 1/2" - 3"	----	Y20S2530	109.95
2"	2 1/2" - 3"	60°	Y20S2530-60	139.95
2 1/8"	2 1/2"	----	Y21S2525	99.95
2 1/8"	2 1/2" - 3"	----	Y21S2530	109.95
2 1/8"	2 1/2" - 3"	60°	Y21S2530-60	139.95
2 1/8"	2 3/4" - 3 1/2"	----	Y21S2735	109.95
2 1/8"	2 3/4" - 3 1/2"	60°	Y21S2735-60	139.95
2 1/4"	2 1/2" - 3"	----	Y22S2530	109.95
2 1/4"	2 1/2" - 3"	60°	Y22S2530-60	139.95
2 1/4"	2 3/4" - 3 1/2"	----	Y22S2735	109.95
2 1/4"	2 3/4" - 3 1/2"	60°	Y22S2735-60	139.95
2 1/2"	2 3/4" - 3 1/2"	----	Y25S2735	109.95
2 1/2"	2 3/4" - 3 1/2"	60°	Y25S2735-60	139.95

Extensions

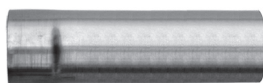

LENGTH	2 1/2" DIA. #	PRICE	2 3/4" DIA. #	PRICE	3" DIA. #	PRICE	3 1/2" DIA. #	PRICE	4" DIA. #	PRICE	5" DIA. #	PRICE
12"	120025	17.95	120027	17.95	120030	17.95	120035	18.95	120040	22.95	120050	31.95
24"	240025	22.95	240027	22.95	240030	22.95	240035	24.95	240040	30.95	240050	42.95
30"	300025	25.95	300027	25.95	300030	25.95	300035	27.95	300040	33.95	----	----
36"	360025	29.95	360027	29.95	360030	29.95	360035	31.95	360040	38.95	360050	59.95
46"	480025	34.95	480027	34.95	480030	34.95	480035	37.95	480040	46.95	480050	76.95

All extensions are expanded on one end

Tractor/Derby Crossover 180° Crossover Stock Clip Street Stock Chassis IMCA Mod. Dirt Late Model Sprint Midget Chassis Applications Mufflers
 Dirt Mod. 4 Cyl. Drag Collectors Flanges/Gaskets U & J Bends X & Y Pipes Turnouts & Extensions Elbow Applications Misc.

Tab Kits



Tab kits include Tabs, Bolts, Lock Nuts and Washers. (except 4001-12)

PART #	DESCRIPTION	PRICE
4003-2	4 TABS/2 BOLTS/2 LOCK NUTS/4 WASHERS	10.95
4003-4	8 TABS/4 BOLTS/4 LOCK NUTS/8 WASHERS	19.95
4003-6	12 TABS/6 BOLTS/6 LOCK NUTS/12 WASHERS	25.95
4000-6	6 BOLTS/6 LOCK NUTS/12 WASHERS	8.95
4001-12	12 TABS (TABS ONLY)	20.95

Exhaust Elbows

DIAMETER	ANGLE°	CLR	A LENGTH	B LENGTH	PART #	PRICE
2"	42°	3"	2 1/2"	13"	2042L	17.95
2"	52°	3"	2 1/2"	13"	2045R	17.95
2 1/4"	42°	3 1/2"	2 1/2"	13"	2242L	17.95
2 1/4"	52°	3 1/2"	2 1/2"	13"	2245R	17.95
2 1/2"	30°	4"	6"	6 3/4"	2531	26.95
2 1/2"	42°	4"	10"	10"	2542	26.95
2 1/2"	45°	4"	5 1/4"	4 3/4"	2545	26.95
2 1/2"	80°	4"	5 1/4"	6"	2580	26.95
2 1/2"	90°	4"	5"	5 1/4"	2590	26.95
2 3/4"	30°	5"	6"	6 3/4"	2731	29.95
2 3/4"	30°	5"	15 1/2"	6"	2732	29.95
2 3/4"	42°	5"	10"	10"	2742	29.95
2 3/4"	45°	5"	5"	6"	2745	29.95
2 3/4"	80°	5"	1 5/8"	1"	2781	29.95
2 3/4"	90°	5"	4 1/2"	4 1/2"	2790	29.95
3"	30°	5"	6"	10"	3013	26.95
3"	42°	5"	2"	11 1/2"	3042L	26.95
3"	52°	5"	2"	11 1/2"	3045R	26.95
3"	30°	5"	6"	6 3/4"	3031	26.95
3"	34°	5"	1 1/4"	6 3/4"	30310	29.95
3"	30°	5"	15 1/2"	6"	3032	26.95
3"	42°	5"	10"	10"	3042	26.95
3"	45°	5"	5"	6"	3045	26.95
3"	60°	5"	5"	6"	3060	26.95
3"	60°	5"	1 1/4"	6"	30610	29.95
3"	80°	5"	4 1/2"	4 1/2"	3080	26.95
3"	80°	5"	1 5/8"	5"	3081	26.95
3"	90°	5"	4 1/2"	4 1/2"	3090	26.95
3"	90°	5"	2"	2 1/2"	3091	26.95
3 1/2"	30°	5"	6 1/4"	6"	3531	26.95
3 1/2"	34°	5"	1 1/4"	6 3/4"	35310	30.95
3 1/2"	30°	5"	15 1/2"	6"	3532	26.95
3 1/2"	42°	5"	10"	10"	3542	26.95
3 1/2"	45°	5"	6"	3 1/2"	3545	26.95
3 1/2"	60°	5"	6"	2"	3560	26.95
3 1/2"	60°	5"	2"	2"	35610	30.95
3 1/2"	80°	5"	6"	2 3/4"	3580	26.95
3 1/2"	90°	5"	6"	2 3/4"	3590	26.95
3 1/2"	90°	5"	2"	2 1/2"	3591	26.95
4"	45°	6"	6 1/2"	8 1/2"	*4045	38.95
4"	90°	6"	3"	3"	*4090	38.95
5"	45°	6"	6"	6"	5045	57.95
5"	90°	6"	3"	3"	5090	57.95

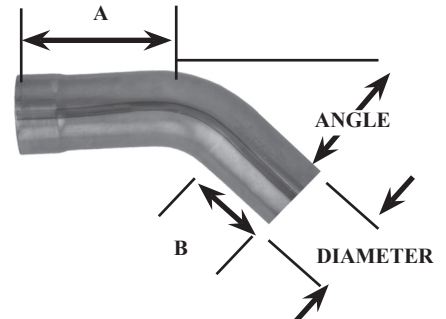

CLR = Center Line Radius*
 All elbows and turn outs are expanded on A end

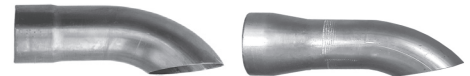

Turnouts

Part # 2525-3 slips over 3"
 Part # 3025-35 slips over 3 1/2"

SIZE	LENGTH	PART #	PRICE
2"	8"	2025	18.95
2 1/4"	8"	2225	18.95
2 1/2"	10"	2525-3	27.95
2 1/2"	10"	2525	21.95
2 3/4"	8"	2724	24.95
2 3/4"	10"	2725	24.95
3"	4 1/4"	3023	23.95
3"	8"	3024	23.95
3"	10"	3025	21.95
3"	10"	3025-35	26.95
3"	15 1/2"	3026	26.95
3 1/2"	4 1/2"	3523	23.95
3 1/2"	8"	3524	23.95
3 1/2"	10"	3525	21.95
3 1/2"	15 1/2"	3526	26.95
4"	10 1/2"	*4025	35.95
5"	12"	5025	53.95

*Aluminized



Exhaust System Applications

2 x 1 Collectors

INLET DIA.	3" OUT #	3 1/2" OUT #	4" OUT #	5" OUT #	PRICE
3" I.D.	Y3030	Y3035	Y3040	Y3050	109.95
3 1/2" I.D.	-----	Y3535	Y3540	Y3550	109.95

2 x 2 Collectors

INLET DIA.	2 1/2" OUT #	3" OUT #	3 1/2" OUT #	PRICE
2 1/2" I.D.	X2525	-----	-----	179.95
3" I.D.	-----	X3030	X3035	179.95
3 1/2" I.D.	-----	X3530	X3535	179.95



Right Side Elbow
(See Chart Below)

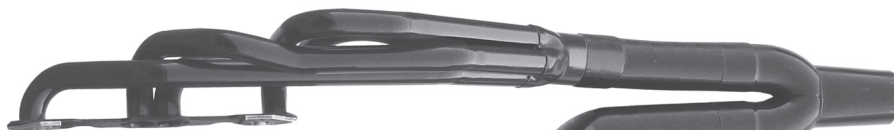

2x2 and 2x1 collectors are designed for easy muffler and tailpipe installation.

Left Side Elbow
(See Chart Below)

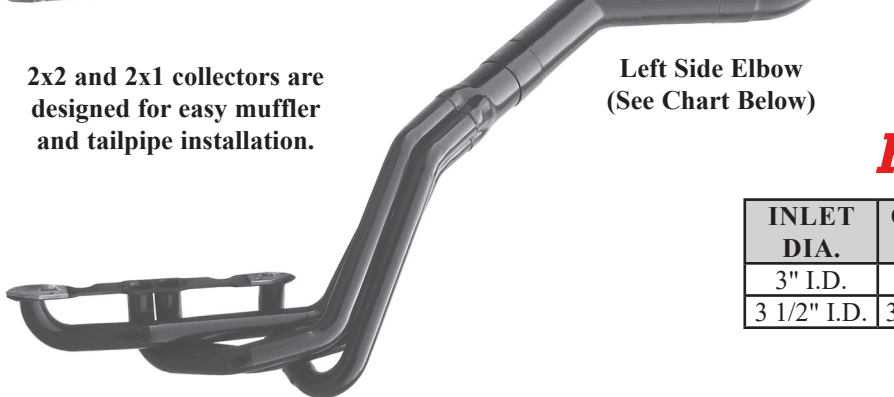

Crossover style headers as listed on page 3-5
(Elbows, 2x2 and 2x1 collectors not included with headers.)

For Mufflers, See Pages 49-50

H Pipes

INLET DIA.	OULET DIA.	PART#	PRICE
3" I.D.	3" I.D.	H3030	99.95
3 1/2" I.D.	3 1/2" I.D.	H3535	99.95



HEADER STYLE	LEFT SIDE #	PRICE	RIGHT SIDE #	PRICE	TOTAL PRICE
134V, 134VH, 135, 135V-3, 135H, 335	3042	26.95	3031	26.95	53.90
135VY, 135VYCM, 335VY, 335VYE	1-3045	26.95	1-30310	29.95	86.85
	1-30310	29.95			
135VYLCM	30610	29.95	120030	15.95	45.90
135V, 135VH, 136, 136V, 136VH, 335V, 336	3542	26.95	3531	26.95	53.90
	35610	30.95			
136V3YG	1-3545	26.95	1-35310	30.95	88.85
136V3Y, 336V3Y	1-35310	30.95			
136V3YL	35610	30.95	120035	16.95	47.90
145, 445	3032	26.95	3031	26.95	53.90
145V, 146, 146V, 445V, 446	3532	26.95	3531	26.95	53.90
179-1	480030	31.95	480030	31.95	63.90
179V-1, 180-1	480035	33.95	480035	33.95	67.90
179-2	360030	26.95	360030	26.95	53.90
179V-2, 180-2	360035	28.95	360035	22.95	57.90
D180, D180V, H180, H180V	1-3535	11.95	-----	-----	11.95

Tractor/Derby
 Dirt Mod.
 Crossover
 4 Cyl. Drag
 180° Crossover
 Collectors
 Flanges/Gaskets
 Stock Clip
 Street Stock
 Chassis
 U & J Bends
 IMCA Mod.
 Dirt Late Model
 Chassis
 X & Y Pipes
 Turnouts & Extensions
 Sprint
 Midget
 Chassis Applications
 Misc.
 Elbow Applications
 Mufflers

Tail Pipe Savers



45° SINGLE



STICKS 4" INSIDE THE DOOR

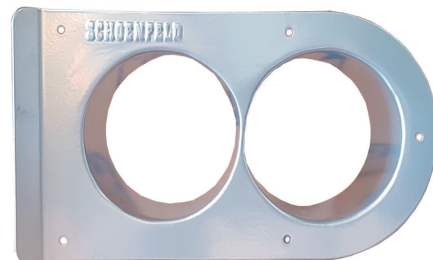

STRAIGHT DUAL

DESCRIPTION	PART #	PRICE
3" SINGLE OUTLET BLACK POWDER COATED	300TSB	90.95
3" SINGLE OUTLET BLACK POWDER COATED 45°	300TSB-45	120.95
3" SINGLE OUTLET SILVER POWDER COATED	300TSS	90.95
3" SINGLE OUTLET SILVER POWDER COATED 45°	300TSS-45	120.95
3" DUAL OUTLET BLACK POWDER COATED	300TSB-2	120.95
3" DUAL OUTLET BLACK POWDER COATED 45°	300TSB-45-2	151.95
3" DUAL OUTLET SILVER POWDER COATED	300TSS-2	120.95
3" DUAL OUTLET SILVER POWDER COATED 45°	300TS-45-2	151.95
3 1/2" SINGLE OUTLET BLACK POWDER COATED	350TSB	90.95
3 1/2" SINGLE OUTLET BLACK POWDER COATED 45°	350TSB-45	120.95
3 1/2" SINGLE OUTLET SILVER POWDER COATED	350TSS	90.95
3 1/2" SINGLE OUTLET SILVER POWDER COATED 45°	350TSS-45	120.95
3 1/2" DUAL OUTLET BLACK POWDER COATED	350TSB-2	120.95
3 1/2" DUAL OUTLET BLACK POWDER COATED 45°	350TSB-45-2	151.95
3 1/2" DUAL OUTLET SILVER POWDER COATED	350TSS-2	120.95
3 1/2" DUAL OUTLET SILVER POWDER COATED 45°	350TSS-45-2	151.95
4" SINGLE OUTLET BLACK POWDER COATED	400TSB	90.95
4" SINGLE OUTLET BLACK POWDER COATED 45°	400TSB-45	120.95
4" SINGLE OUTLET SILVER POWDER COATED	400TSS	90.95
4" SINGLE OUTLET SILVER POWDER COATED 45°	400TSS-45	120.95
5" SINGLE OUTLET BLACK POWDER COATED	500TSB	90.95
5" SINGLE OUTLET BLACK POWDER COATED 45°	500TSB-45	120.95
5" SINGLE OUTLET SILVER POWDER COATED	500TSS	90.95
5" SINGLE OUTLET SILVER POWDER COATED 45°	500TSS-45	120.95

IMCA Mufflers

Temporary non-high temperature paint

LENGTH	WEIGHT	PART #	PRICE	SANCTION APPROVED
6"	1.28#	IMCA609	45.95	IMCA
9"	1.95#	IMCA930	45.95	IMCA
9"	2.30#	IMCA935	45.95	IMCA

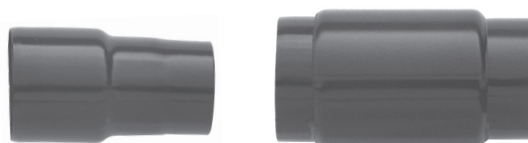



Mufflers

LENGTH	OUTLET DIAMETER	INLET DIAMETER	BODY DIAMETER	PART #	PRICE
6"	3"	3"	3 1/2"	63030	17.95
8"	3"	3"	3 1/2"	83030	17.95
12"	3"	3"	3 1/2"	123030	25.95
6"	3 1/2"	3 1/2"	4"	63535	17.95
8"	3 1/2"	3 1/2"	4"	83535	17.95
8"	4"	4"	4"	84040	29.95
9"	3 1/2"	3 1/2"	4 3/8"	92535	45.95
12"	3 1/2"	3 1/2"	4"	123535	29.95
12"	4"	4"	4"	124040	32.95
14"	3 1/2"	3 1/2"	4 1/2"	14272535	76.95
17"	3 1/2"	3"	4 1/2"	14272530	93.95
17"	3 1/2"	3"	4 1/2"	14272730-78	93.95
27"	4"	4"	4 1/2"	273540	71.95

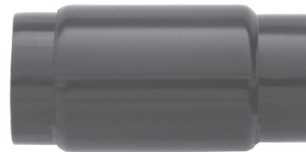

Temporary non-high temperature paint



95 DB Muffler
 At 4 pounds



LENGTH	WEIGHT	PART #	PRICE	SANCTION APPROVED
11"	2.84#	112535	45.95	ALL-STAR
11"	2.35#	112530	45.95	-----
11"	2.40#	113035	45.95	-----
14"	4.00#	14272735-78	76.95	W.O.O - ASCS

Insert Reducer & Muffler

With it's straight through design, the Schoenfeld Insert Muffler reduces noise without excess back pressure. The insert is light weight with nothing to burn out.

Reducers

Mufflers

COLLECTOR DIAMETER	LONG	CORE DIAMETER	PART #	PRICE
3"	4"	2 1/2"	42530NH	17.95
3 1/2"	4"	2 1/2"	42535NH	17.95
3 1/2"	4"	3"	43035NH	17.95
4"	4"	3 1/2"	43540NH	23.95

COLLECTOR DIAMETER	LENGTH	CORE DIAMETER	PART #	PRICE
3"	4"	2 1/2"	42530	17.95
3 1/2"	4"	3"	43035	17.95
4"	4"	3 1/2"	43540	23.95
4"	24"	3 1/2"	243540	29.95

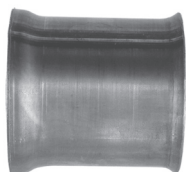

Chassis Applications Midget Sprint Dirt Late Model IMCA Mod. Chassis Street Stock Stock Clip 180° Crossover Collectors Drag 4 Cyl. Tractor/Derby Dirt Mod. Mufflers Elbow Applications Misc. Turnouts & Extensions X & Y Pipes U & J Bends Flanges/Gaskets Crossover Collectors Drag 4 Cyl. Tractor/Derby Dirt Mod.

Anti-Reversion Chamber Muffler

LENGTH	OUTLET DIAMETER	INLET DIAMETER	BODY DIAMETER	PART #	PRICE
12 1/2"	3"	3"	4 3/8"	112530ART	79.95
11"	3 1/2"	3"	4 3/8"	112530AR	65.95
11"	3 1/2"	3 1/2"	4 3/8"	112735AR	65.95

Temporary non-high temperature paint



FedEx Ground Shipping Schedule

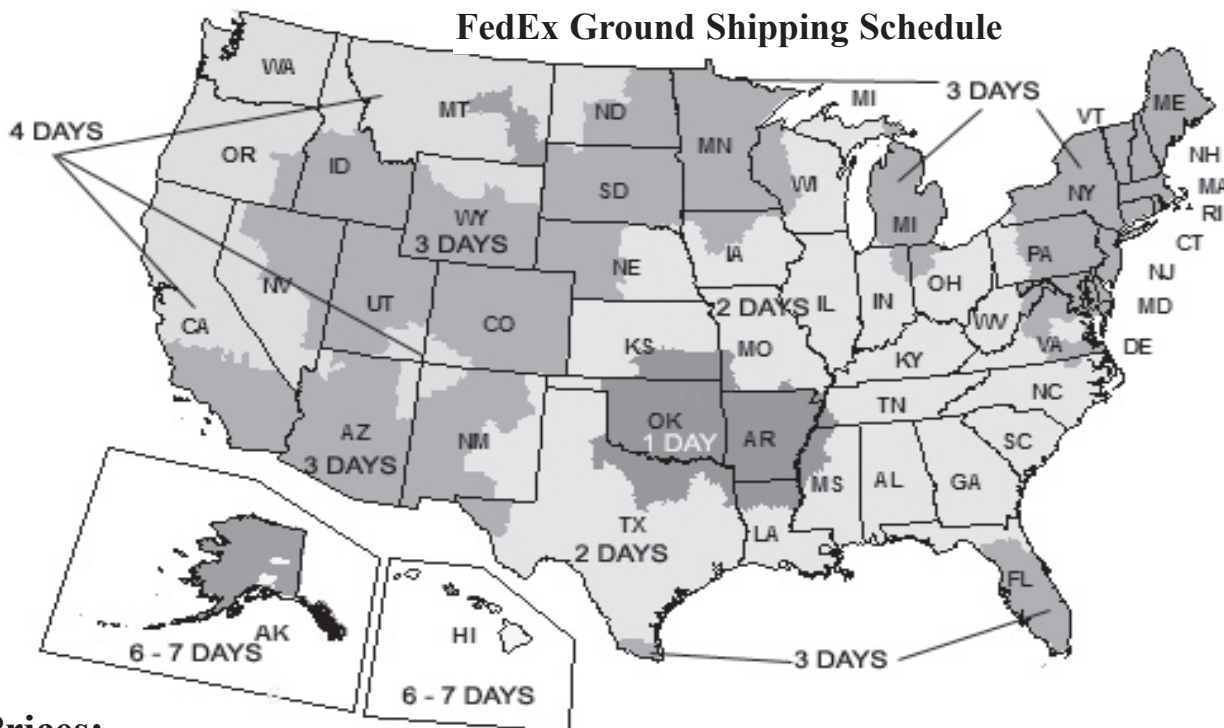

Prices:

All prices in this catalog are effective July 1st, 2023 and are subject to change without notice. Prices do not include shipping.

Shipping:

We ship FedEx Ground (preferable), motor freight and air freight.

Drop Shipment:

Drop Shipments will be charged a \$10.00 fee per order.

Returns:

All returns must be authorized with an RMA # and accompanied by a copy of the original invoice, with a note describing reason for return. The RMA # must be written on the box. Returns must be shipped pre-paid; no C.O.D. returns will be accepted. Any refused shipment returned to Schoenfeld Headers Inc., will be subject to a freight chargeback. Further orders will be delayed until charges are paid. No returns on special orders or obsolete parts.

Restocking Charge:

Restocking Charge of \$20.00 per box.



Performance • Quality • Value

CONGRATULATIONS

2023

Champions

Thank You For Choosing Schoenfeld Headers



**605 S. 40th St.
Van Buren, AR 72956**



Made in USA

www.SchoenfeldHeaders.com